

SEE THE SIGNAL

A NEW SYSTEM

OF

DYNAMIC ANALYSIS

by

SUPREME

INSTRUMENTS CORPORATION

GREENWOOD

MISSISSIPPI, U.S.A.

PRICE 35 ¢

SUPREME

INSTRUMENTS CORPORATION

GREENWOOD, MISSISSIPPI U. S. A.

The primary purpose of "SEE THE SIGNAL" is to present the application notes for the cathode ray type of dynamic analyzer in a convenient, practical form. This book has been prepared from data supplied by the engineering and service departments of the Supreme Instruments Corporation. General information concerning the theory of the components may be found in any modern text book on video amplification, and thus the major part of this treatise will deal directly with its application as a service instrument.

In an effort to make the explanation of the procedure as clear as possible, a large part of the discussion is illustrated by diagrams of typical circuits and results to be expected on the screen of the cathode ray tube. Point by point descriptions of the relative magnitudes and conditions of the signal under various circumstances are shown for circuits found in the average radio receiver.

The order of the presentation has been so arranged as to familiarize the operator with the operation of the dynamic analyzer as individual sections and then as the complete system. The first part gives the operator the preliminary set-up of the equipment and a general working knowledge of the components. The remainder of the book contains the application notes with the illustrative oscillograms. Of course, the reader should bear in mind that certain variations in the oscillograms are to be allowed for the individual characteristics of the receiver determined by the cost and design.

As the operator becomes familiar with the general operation of the VEDCLYZER, many will find new and epoch-making applications not included within this book. For this reason technicians and engineers will conclude that they have an instrument which has innumerable possibilities of utilization.



INTRODUCTION

Some several thousand years ago there was written a famous Chinese proverb "A picture is worth a thousand words", which is today a popular quotation among the members of the radio servicing industry. Little did this ancient philosopher know that he was predicting the future ideal method of servicing the radio receiver -- "SEE THE SIGNAL". Even the servicemen of several years ago would have thought such an idea as seeing the pictures of a radio signal a mere dream. The average technician or student of radio usually took the diagrams in his radio text books for granted or possibly wondered if the author were not over-working his imagination.

The procedure for testing a radio receiver has been changed considerably since the introduction of commercial testing equipment. There are many servicemen of the old school who can well remember the days when a voltmeter with a sensitivity of not more than 100 ohms per volt was the only device available to check the static condition of the radio receiver. As time progressed, the voltmeter was equipped with a battery and calibrated in ohms and we had the fundamental functions for a static analyzer. With this set-up the serviceman could check the static operating conditions such as voltage, current, ohms, etc., frequently referred to as "free point analysis", "point to point", testing and the like. In this day, receiving sets were simple in construction, most of them not exceeding two or three tubes using a tuned radio frequency (t-r-f) circuit. The power was supplied by batteries, thus eliminating the hum which we frequently have in the modern a-c superhetrodyne. The introduction of the superhetrodyne was the beginning of a new era in radio servicing. The invention of this circuit made the signal generator an essential part of the test equipment in the service laboratory due to the need of a controlled source of signal supply for the proper alignment of the intermediate frequency transformers. At this time, the output meter was utilized to peak the i-f stages using an amplitude modulated signal.

In the early part of 1930, the radio service industry knew that a simpler and more accurate means of aligning the receiver had to be developed. The cathode ray oscilloscope was the answer. Most servicemen were a little doubtful for two rather good reasons: First, the cost of the equipment was almost prohibitive and second, it was a difficult instrument to operate due to the small amount of literature available on the subject. In the average serviceman's opinion, it almost required a "super" radio engineer to identify the figures upon the screen of a cathode ray tube. Knowing this to be merely a false supposition, the Supreme Instruments Corporation introduced double image alignment which led to the method of dynamic analysis utilizing the oscillograph - SEE THE SIGNAL.

The cathode ray tube, which is the heart of the oscillograph, is a much older device than many people suspect. The first tube of this type was introduced in the latter part of the nineteenth century, known as the "Braun Vacuum-Tube" after its inventor. Scientists used the cathode ray tube for making observations of alternating currents at low frequencies. The operation as a scope was not popular even in the research laboratory due to the difficulty in obtaining the high operating potentials and the frequency limitations. It was necessary to get the voltages from batteries, inasmuch as the modern power rectifier was not considered practical. However, these difficulties have been overcome and for quite some time the oscillograph has occupied its rightful place in the radio industry. The oscillograph of today is a completely self-contained unit of a convenient size and as simple to operate as a pushbutton multimeter.

Dynamic testing of a radio receiver is not a radically new system; it has won much favor only since it was made available to the serviceman by test equipment manufacturers in a convenient manner at reasonable cost. The modern form of dynamic testing was introduced as "Signal Tracing" which is the reverse of "Signal Injection". The signal tracer proved to be extremely effective in locating many defects which were very difficult to find with static testing instruments such as the volt, ohm or capacity meter and free point analysis systems. But the signal tracer fell short in making an efficient dynamic tester due to its inability to indicate the condition of the signal as well as the relative

amplitude, and thus the dynamic analyzer was introduced to meet the requirements of the service engineer.

The "SEE THE SIGNAL" system is Supreme's conception of utilizing the most logical equipment and methods for dynamic testing. Thus the procedure must be simple and the instrument must be a Dynamic Analyzer.

It is important to understand the difference between the dynamic signal tracer and the dynamic analyzer. Any device whose indicators reveal the presence of a signal, the relative amplitude of the signal, and the frequency of the signal may be termed a Dynamic Signal Tracer. However, for an instrument to be termed a dynamic signal analyzer it must not only incorporate facilities for indicating the function of the signal tracer but it must also contain an indicator which will determine the QUALITY of the signal. In other words, the primary purpose of dynamic signal tracing is to determine the presence or absence of the signal at its proper points and indicate its relative amplitude and frequencies. Dynamic analysis not only reveals to the operator the presence, amplitude and frequency of a signal but it also reveals the QUALITY of the signal.

The "SEE THE SIGNAL" system, employing the VEDOLYZER as the Dynamic Analyzer, is a revelation in modern servicing. Thus, the vast possibilities and applications for such a versatile instrument and system can by no means be confined to the information found within the contents of a single volume.

-- OPERATING INSTRUCTIONS FOR THE VEDOLYZER --

The Supreme Model 560-A is a complete dynamic analyzer for checking radio receivers, parts, and associated electronic apparatus under actual operating conditions. It incorporates a vacuum-tube multimeter, cathode ray oscillograph, wavemeter, signal tracer and a multiple monitoring system. The VEDOLYZER may be used wherever it is necessary to check the amplitude and condition of the voltage in practically any type of electrical device.

The VEDOLYZER is a quality instrument throughout, designed to provide that professional appearance combined with durability and maximum utility found in SUPREME products. Inside the unit will be found the usual fine workmanship of Supreme's craftsmen and technicians and the highest quality parts the market affords. Some of the more important features show why Supreme is proud to be once again a pioneer in a new system of analysis that has met with the approval of the radio industry in general.

VACUUM-TUBE MULTIMETER

The vacuum-tube multimeter is designed with the characteristics of the single tube bridge-type V.T.VM. providing maximum stability and accuracy of calibration. Functions are included in the multimeter section for checking a-c voltage, d-c voltage and resistance with all ranges controlled by seven fast action push buttons.

DC VOLTMETER at 15 megohms input impedance - 0/2/6/20/60/200/600 voltage ranges.

DC VOLTMETER at 150 megohms input impedance - 0/20/60/200/600/2000/6000 voltage ranges.

AC VOLTMETER at 15 megohms input impedance - 0/3/9/30/90/300/900 voltage ranges.

AC VOLTMETER at 150 megohms input impedance - 0/30/90/300/900/3000 voltage ranges.

R.F. METER with 3 megohms input resistance at 1.5 mmf. input capacitance.

OHMMETER - single zero adjustment for all ranges - 0 to 1000/10M/100M/1MdG/10Meg/100Meg/1000Meg. 10 ohms center scale on low range.

CATHODE RAY OSCILLOGRAPH

The oscillograph section contains the well-known SUPREME OSCILLOSCOPE with a special high gain, wide range vertical amplifying system. The wide range amplifier incorporates a special video circuit which provides a frequency response with virtually flat characteristics from 20 cycles to 2.5 megacycles. The input resistance is 3 megohms with an input capacitance of only 1.5 micromicrofarads. The input of the vertical amplifier is equipped with a frequency compensated, accurately calibrated multiplier and attenuator network providing an attenuation ratio of 100,000 to 1, independent of the frequency.

VERTICAL DEFLECTION SENSITIVITY WITH VIDEO (red) PROBE: (input resistance 3 megohms - input capacitance 1.5mmf.) Approximately .50 volts (RMS) per inch deflection.

VERTICAL DEFLECTION SENSITIVITY WITH AUDIO (black) PROBE: (.5 megohms) Approximately .15 volts per inch deflection.

VERTICAL DEFLECTION SENSITIVITY WITHOUT ISOLATION PROBE: Approximately .02 volts (RMS) per inch deflection.

The internal sweep generator uses a standard thyatron oscillator tube for producing horizontal deflection at frequencies of 20 to over 30,000 cycles. Means are provided for internal and external synchronization for both the r-f and a-f signals.

DYNAMIC SIGNAL TRACER AND MULTIPLE MONITORING SYSTEM

The signal tracing and multiple monitoring system provide special probes and inputs to the dynamic indicators-- the r-f meter and the 'scope. This makes possible the tracing of the signal through the r-f, i-f and a-f amplifiers and at the same time checking for distortion, amplitude and hum as well as the continuity.

In amplitude modulation receivers this section provides a simple and accurate means of checking the signal for amplitude, frequency, waveform, gain, percent of modulation, r-f, i-f and a-f distortion. In the frequency modulation receiver the i-f signal may be checked for the above mentioned conditions together with an analysis of the limiter and discriminator action. Televisions receivers will reveal the vertical and horizontal deflection generator voltage, yoke current, synchronizing separator action -- composite video signal from detector to kinescope grid and also the low and high frequency compensation of the video amplifiers for maximum resolution.

Checking for intermittents is just part of the routine for the VEDOLYZER. Three sections may be connected to the input of the dynamic analyzer at the same time and when the trouble appears, it is just a matter of a slight bit of signal tracing in the indicated defective stage to reveal the faulty component.

THE WAVEMETER

The wavemeter is incorporated for the purpose of determining the frequency of the voltages between 65kc. and 6.5mc. This section may be automatically switched into the signal tracing section simply by turning a knob and adjusting the dial for maximum amplitude on the scope and r-f meter.

THE SECTIONS OF THE VEDOLYZER

The cathode ray oscillograph section contains a three inch, high vacuum, electrostatic, cathode ray tube. The internal power supply for the unit is powered by two type 884 thyatrons to provide a linear sweep which covers a range of 20 to over 30,000 cycles.

The vertical amplifier uses 3 type 1852 tubes and one type 6AG7. These tubes are arranged in a specially designed circuit to provide a frequency response from 20 cycles

to 2.5mc. with an undistorted gain of 100db.

The wavemeter uses one type 1852 in conjunction with a four band tuner covering a range from 65kc. to 6.5mc. A large illuminated dial is controlled by a laboratory type tuning knob on a shaft with a 5 to 1 reduction mechanism. The video amplifier may be used with or without the tuning unit.

The horizontal amplifier is a conventional resistance-coupled stage using a type 6SJ7 tube. The frequency range of this section is from 10 cycles to 100 kilocycles with a maximum gain of 40db.

The vacuum-tube voltmeter uses a type 6J5 tube occupying one arm of a bridge-type resistance circuit. The multiplier resistors in the V.T.VM. grid circuit have a 1% tolerance and an input impedance of 15 or 150 megohms. The ohmmeter section of the multimeter is powered by an internal battery of standard type.

A UNIVERSAL INSTRUMENT

Although the VEDOLYZER has made quite a record in the radio service industry, it has found its place in leading radio laboratories, power plants and educational institutions. The oscillograph by its very nature, being an instrument capable of indicating in two dimensions, has unlimited applications in a wide variety of commercial fields.

THE VEDOLYZER AS AN INSTRUMENT FOR RADIO SERVICE

When used with the Supreme Model 561 combination signal generator, the VEDOLYZER provides the technician with an ideal service laboratory set-up. By adding a tube checker to the above mentioned combination the set-up is complete to handle every job at a profit. In addition to the use of the instrument as a dynamic analyzer for trouble shooting and signal tracing the following applications illustrate the use of the "SEE THE SIGNAL" system.

Fast accurate alignment with the famous Supreme Double Image system provides a method which is the fastest and most accurate ever introduced for visual adjustment of the r-f, i-f and AFC stages. Instantaneous selectivity measurements and fidelity tests together with comparative sensitivity checks. Frequency runs, power output and overload tests indicate the condition of the motion picture or P.A. sound equipment.

When used with a square wave signal generator having a frequency of from 60 cycles to 70 kilocycles the 'scope section may be used to visually check the response of high fidelity and video amplifiers for high and low frequency compensation.

ELECTRICAL SPECIFICATIONS

Power Supply Requirements: (unless otherwise specified on plate attached to grill in rear of chassis)

Voltage.....	110/125 volts AC
Frequency.....	60 cycles
Power Consumption.....	75 watts
Fuse Protection.....	2 amperes

MECHANICAL SPECIFICATIONS

Over-all dimensions:

Height.....	11 $\frac{1}{2}$ inches
Width.....	15 $\frac{1}{2}$ inches
Depth.....	12 inches

Weights:

Net..... 35 pounds
 Shipping..... 40 pounds

STANDARD EQUIPMENT SUPPLIED WITH THE MODEL 560-A

QUANTITY INCLUDED	STOCK NUMBER	DESCRIPTION
1	5286	Booklet, Instruction "SEE THE SIGNAL"
1	6725	Card, Return Registration
1	6288	Chart, Sample Analysis
1	7682	Screen, Calibrated non-linear
1	5198	Probe, coaxial cable (red) R.F. Video
1	4808	Probe, coaxial cable (blue) I.F.
1	5199	Probe, shielded cable, A.F.

DESCRIPTION OF PANEL AND COMPONENTS

METER - Three inch round D'arsonval type.

Scales:

OHMS - 0 to 100 non-linear with 1.5 mark near center. For resistance and continuity measurements with ohms and megohms functions.

D.C. VOLTS - 0/2/6 basic d-c volts scales.

A.C. VOLTS - 0/3/9 basic a-c volts scales.

SOCKET - (Lower center of panel labeled "VIDEO-R.F.") Red probe input connector for signal tracing and analysis.

SOCKET - (Lower center of panel labeled "I.F.") Blue probe input connector for multiple monitoring section.

SOCKET - (Lower center of panel labeled "A.V.C.-A.F.") Black audio probe input connector for signal tracing, A.F. analysis and A.V.C. voltage measurements.

PANEL - Black "Cro-art" finish - Aluminum and red highlights - Size 11 $\frac{1}{2}$ X 15 $\frac{1}{2}$ inches.

PUSH BUTTONS - (Left edge of panel) 7 buttons: "VOLTS OHMS". Range selector for multi-meter section. Volts A.C.-0/3/9/30/90/300/900. Volts D.C.- 0/2/6/20/60/200/600. Reading (R) X 10/100/1M/10M/100M/1Meg/10Meg.

PUSH BUTTONS - (Right edge of panel) 7 buttons "SWEEP FREQ." Range selector for saw-tooth generator in oscillograph section. Rough Frequency selection 1/65/230/950/3M/10M/30M.

PUSH BUTTONS - (Center of panel labeled "MULTIPLIER") 4 buttons: 1/10/100/1000. Range selector for attenuation of all signals going into the vertical amplifier.

PUSH BUTTONS - (Center of panel labeled "A.V.C.", "VIDEO R.F.", "I.F.", "A.F.") Probe switches for connecting red, blue and A.F. probes to VEDOLYZER inputs.

PIN JACKS - (Left side of panel) 3 jacks: "VOLTS X 10" , "V.T.VM.†" and "GND". External connections to vacuum-tube multimeter.

PIN JACKS - (Right side of panel) 3 jacks: "GND", "EXT.SYNC" and "EXT.SWEEP". Used in conjunction with oscillograph for external sweep and synchronization purposes.

- HEXAGON KNOBS - (Upper left side of panel labeled "HOR.POS." and "VERT.POS.") For centering spot or image on screen of cathode ray tube.
- HEXAGON KNOBS - (Upper right hand side of panel labeled "INTENSITY" and "FOCUS") For adjusting the brilliance and definition of the image or spot on the screen of the cathode ray tube.
- ROTARY POTENTIOMETER - (Left side of panel labeled "ZERO VOLTS") For preliminary adjustment of vacuum-tube voltmeter.
- ROTARY POTENTIOMETER - (Left side of panel labeled "ZERO OHMS") For preliminary adjustment of ohmmeter.
- ROTARY POTENTIOMETER - (Right side of panel labeled "SYNC.CONTROL") For adjusting amplitude of synchronizing voltage, causing image of cathode ray tube to become stationary.
- ROTARY POTENTIOMETER - (Right side of panel labeled "FINE FREQ.") For vernier adjustment for saw toothed generator of oscillograph section.
- ROTARY POTENTIOMETER - (Right side of panel labeled "VERT.GAIN") Input control for signal tracing and analysis section.
- ROTARY POTENTIOMETER - (Right side of panel labeled "HOR.GAIN") For controlling length of horizontal line on cathode-ray tube.
- ROTARY SWITCH - (Left side of panel labeled "POWER") "OFF-ON" switch for connecting external power to the VEDOLYZER.
- ROTARY SWITCH - (Left hand side of panel labeled "FUNCTION SELECTOR") Master switch for automatic operation of instrument. "ACV", "DCV" and "OHMS" multimeter sections when used in conjunction with "V.T.VM.+" and "GND" pin jacks. "DCV" also used in conjunction with "VOLTS X 10" pin jack. "GAIN" amplifier is untuned. "WAVEMETER"(A,B,C,D) Tuned amplifier at frequency indicated on radio frequency dial.
- DIAL - Illuminated (Center of panel controlled by large hexagon knob with flange) For selection of frequencies on bands as indicated by the "FUNCTION SELECTOR" A band 65kc-205kc; B band 205kc.-650kc.; C band 650kc.-2050kc; D band 2050kc-6.5mc.
- CATHODE RAY TUBE - Three inch diameter, high vacuum, medium persistence type.



THE SUPREME VEDOLYZER MODEL 560-A

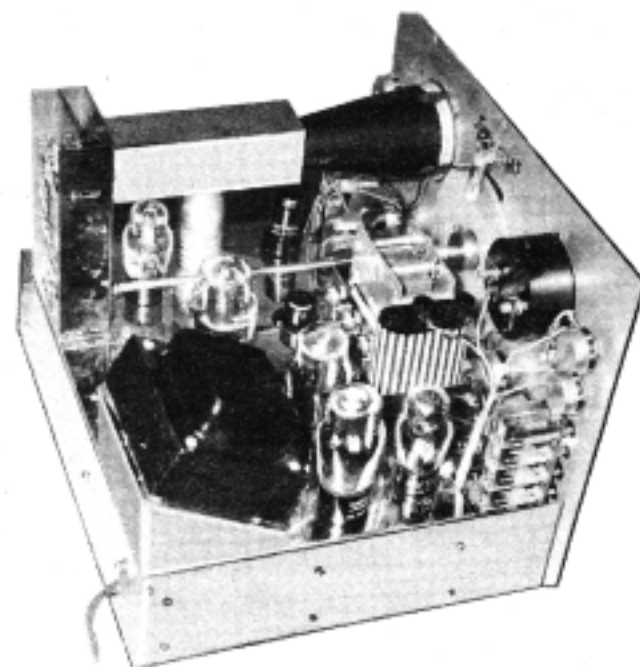

TOP CHASSIS VIEW OF MODEL 560-A

THE VEDOLYZER AS A COMPLETE DYNAMIC ANALYZER

The VEDOLYZER is essentially a super-voltmeter with provisions for analyzing radio or electronic apparatus under actual operating conditions. To accomplish this, the voltmeter must have multimeter functions, input control, wide range frequency response, extremely high amplification, provisions for frequency determination and facilities for observing the quality and quantity of the signal. The block diagram in Fig.1 illustrates the relative electrical positions of the above mentioned components and the following discussion will present the sections with reference to direct application to radio service.

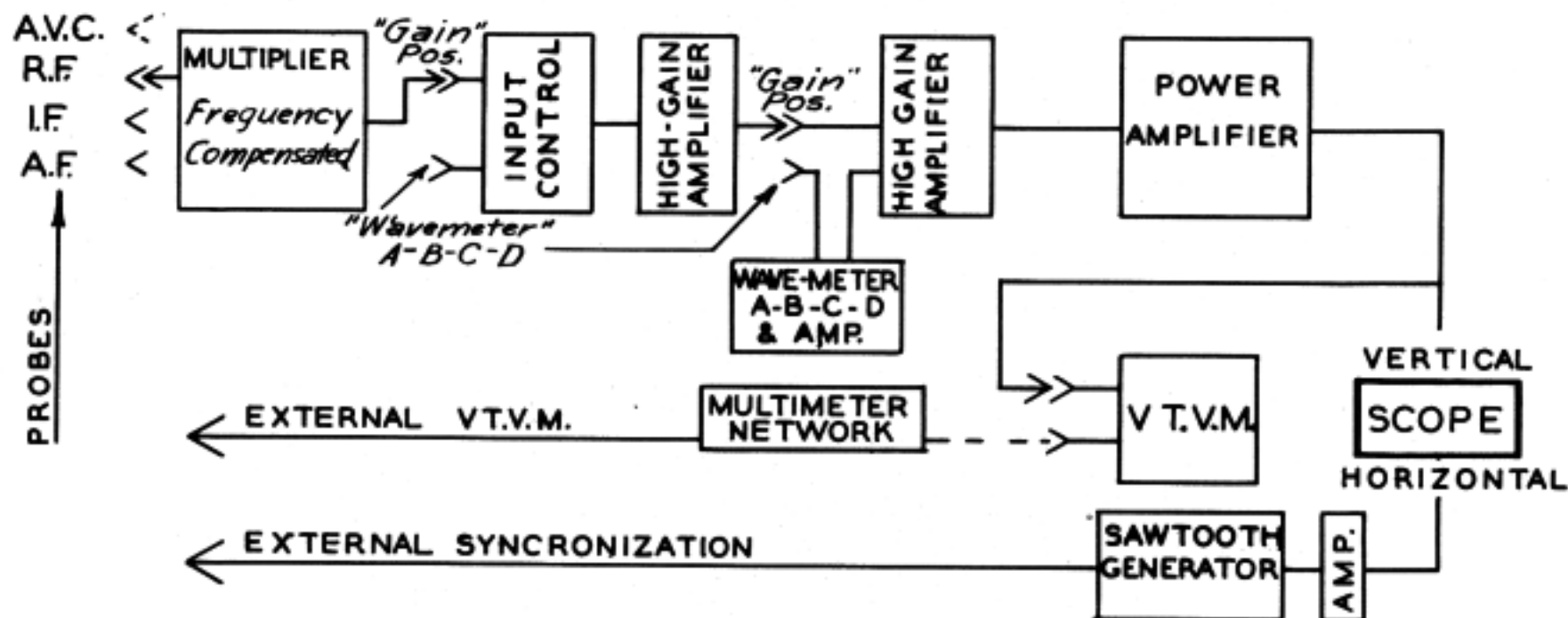

FIG. 1 BLOCK DIAGRAM OF SUPREME MODEL 560-A VEDOLYZER
THE SIGNAL SUPPLY

Since the VEDOLYZER is expected to locate defects in the passage of a signal through the various stages of radio apparatus, a source of signal supply should be used which will produce an exciting voltage of good wave form and sufficient amplitude in order that the operator will have a standard by which to compare the voltage at the various testing points.

The generator or generators which we recommend to be used in conjunction with the VEDOLYZER should have:

- 1 - Sine wave output (A.F. and R.F.)
- 2 - Variable Audio Frequency and Amplitude
- 3 - Metered output level

The Supreme Model 561 Signal Generator was designed to fulfill these requirements and since most owners of the VEDOLYZER have one of these units, it will be used as the source of supply in the discussion of applications.



SUPREME MODEL 561 GENERATOR

PRELIMINARY SET-UP

The VEDOLYZER and Generator may require some preliminary adjustments which should be checked at various intervals. Usually these adjustments are made when the service shop opens for the daily business, and if the line supply is fairly stable, this will suffice until the shop closes. When making the preliminary set-up, all leads should be removed from the VEDOLYZER.

It is also advisable to have the "INTENSITY" control turned in the extreme counter-clockwise

direction to prevent accidentally damaging the cathode ray tube screen.

THE VEDOLYZER AS A MULTIMETER

Referring to the panel layout of Fig.2, the rotary "POWER" switch is located near the lower left hand corner of the VEDOLYZER. This switch controls the primary of the main power transformer which supplies the entire instrument. After this switch is turned "ON" and the usual receiver warming-up period has been allowed, the "FUNCTION SELECTOR" switch (located to right of "POWER" switch) should be turned to "DCV" volts position and the meter adjusted to "0" by means of the "ZERO VOLTS" control (above power switch). Now turn the "FUNCTION SELECTOR" switch to "OHMS" and note the forward deflection of the meter. Adjust "ZERO OHMS" (above "FUNCTION SELECTOR" switch) to full scale deflection. For operation of the multimeter section the functions (DCV,ACV,OHMS) are available at the "V.T.VM.+"

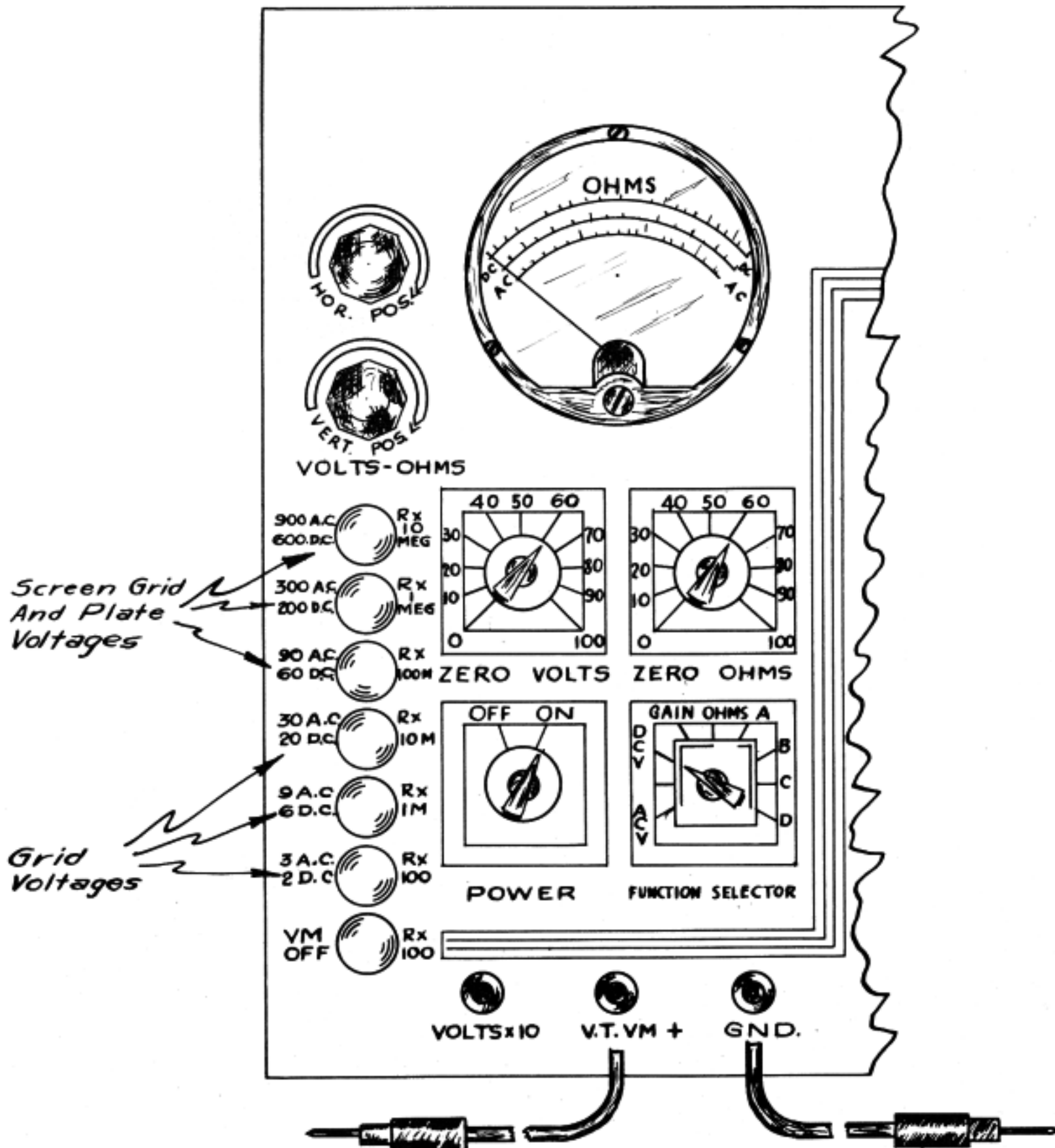

FIG.2 -THE VEDOLYZER AS A MULTIMETER

pin jacks and "GND" using ordinary test leads with pin plug connectors. The ranges are selected by means of the push buttons on the extreme left edge of the panel. For DC voltages above 600 volts use "VOLTS X 10" pin jack instead of "V.T.VM." and multiply range by 10. (600 volt range equals 6000 volts). When changing the "FUNCTION SELECTOR" from "ACV" to "DCV" it may be necessary to make a slight adjustment with the "ZERO VOLTS" control.

THE VEDOLYZER AS AN OSCILLOGRAPH

The scope controls are located in both the upper right and left hand corners. On the left hand side of the meter (Fig.3) are the "VERT.POS." and "HOR.POS." positioning controls for centering or resetting the image or spot. The knobs to the right of the

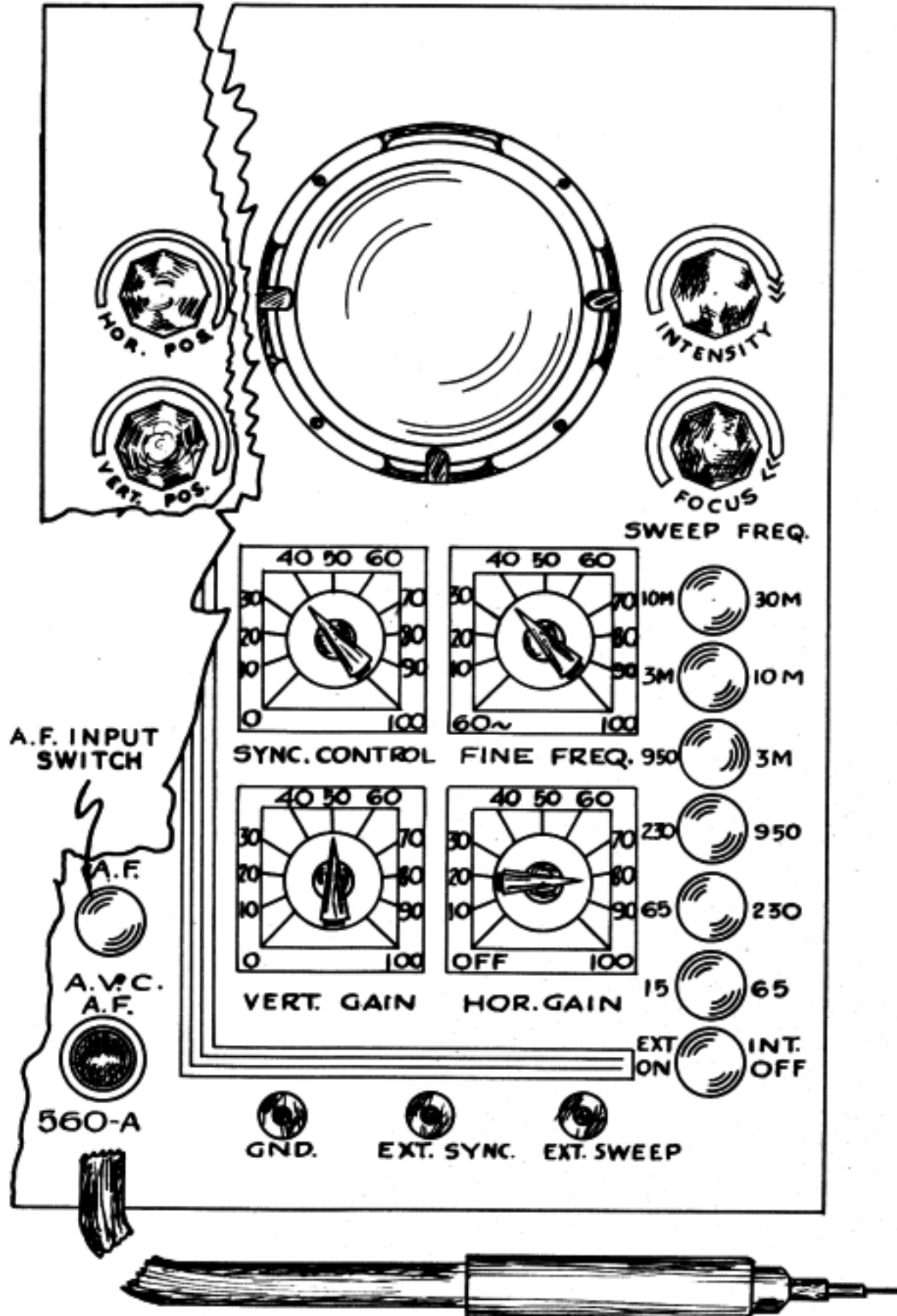

FIG.3 —THE VEDOLYZER AS AN OSCILLOGRAPH

screen of the scope are the "INTENSITY" and "FOCUS" controls for adjusting the brilliance and definition of the image respectively.

Below the tube are two rotary controls, "FINE FREQ." and "SYNC.CONTROL", which are used in conjunction with the push buttons (15-65 etc.) for adjusting the frequency and "locking" the horizontal voltage with respect to the test signal. Directly below these controls are the gain adjustments for the vertical and horizontal amplitudes which are self-explanatory. After adjusting the "INTENSITY" and "FOCUS" controls for a line or a spot, depress a "SWEEP FREQ." button and advance the "HOR.GAIN" until the line on the screen is about two inches long. The "VERT.GAIN" control should be turned to about 100. When a voltage is applied to one of the probes, the sweep frequency should be adjusted with the "FINE FREQ." control until the pattern is almost stationary. To stabilize or "lock" the image advance the "SYNC.CONTROL". The average position of the synchronizing control at which the signal "locks" is about 75 to 100 percent of rotation. This setting depends upon the amount of voltage applied to the vertical input and the amplitude of the "EXT.SYNC." voltage.

The oscillograph may be used in the conventional manner as a separate unit however, the application in this discussion will be as an indicator of the VEDOLYZER. Illustrations of the oscillogram are shown in the figures (A,B,C,D,E,etc.)

THE VEDOLYZER AS A SIGNAL TRACER

As mentioned previously, the VEDOLYZER is a voltmeter capable of indicating in two dimensions the results caused by voltage impulses in an electrical circuit. In other words, the vertical amplitude on the scope and the meter deflection is one dimension and the time factor (horizontal deflection) which makes possible the analysis of the signal is the other dimension. The amplitude may be termed the quantity, and the wave form on the scope the quality of the voltage under test.

To place the VEDOLYZER in position for routine signal tracing, connect the red probe to the "R.F. VIDEO" socket and depress the "R.F. VIDEO" button. Set the "FUNCTION SELECTOR" switch to the "WAVEMETER" position. Refer to the block diagram in Fig.6. Here is shown a typical superhetrodyne receiver with auxiliary sections such as Power Supply, Automatic Frequency Control, Automatic Volume Control, etc.,

The generator should be set up for 400 cycles 30% amplitude modulation and fed to the antenna posts of the receiver. A frequency of 1000kc. makes an ideal testing voltage and we recommend that the signal generator and receiver be tuned to this point. Connect the "A.F. OUTPUT" of the 561 to the "EXT.SYNC." of the VEDOLYZER. The ground lead on the signal generator output is connected to the chassis of the receiver.

In the case of the AC-DC type of receiver the "GND" of the VEDOLYZER should be connected to the chassis of the set under test through a series capacitor of approximately .01 MFD.

Since the VEDOLYZER has two systems of indication and both are of equal importance in locating a defective component of a radio receiver, it will be necessary to show the results on the meter and the scope simultaneously. In order to save space and minimize confusion, the symbols shown in Fig.5 will be used throughout this discussion.

For example, suppose that we place the probe on the input of an amplifier which is being supplied with a modulated R.F. signal. The meter will indicate a deflection which is dependent upon the amplitude of the signal at the amplifier input. The quality or general conditions of the signal will be indicated by the pattern on the screen of the cathode ray tube. The upper circles in Fig.5 illustrate typical results of the meter and scope reading from left to right. If these two circles are superimposed upon each

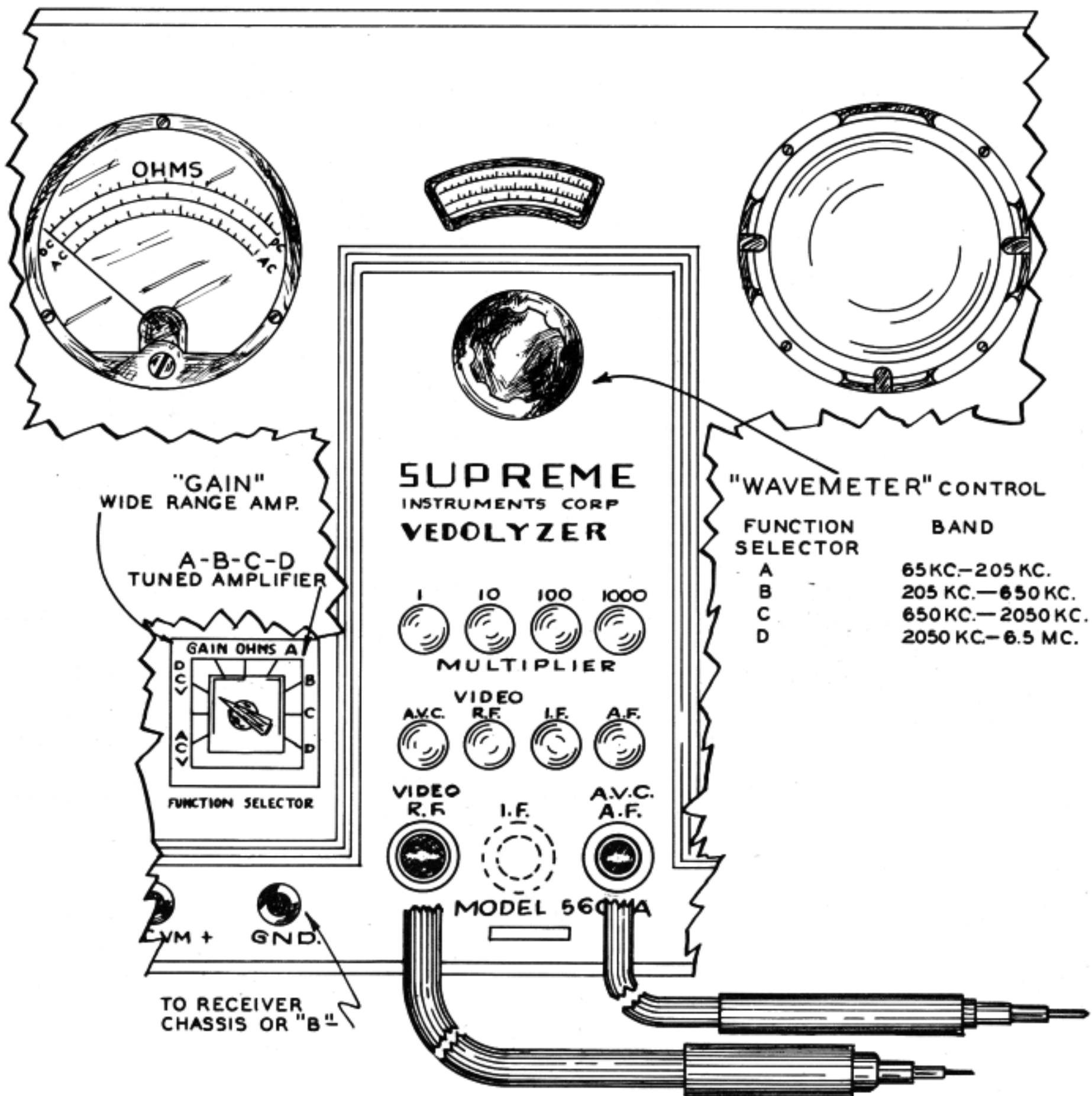

FIG. 4 - THE VEDOLYZER AS A SIGNAL TRACER

other, the symbol shown to the extreme right will indicate the combined results.

In order to clarify this notation a little further, let us place the probe on the output of the amplifier. The meter will show an increase if the stage is amplifying which is represented by the deflection in the lower drawings. The dotted line represents the former position of the needle which would result if no amplification were present in the stage. To the right of this figure, we have the oscillogram with the input waveform shown by the dotted line. The combined oscillogram and meter deflection is shown in the lower right hand corner which should be compared with the circle or symbol directly above it.

Frequently, it is necessary to show DC voltages instead of the AC components on the meter. When such cases arise, a notation will be made directly below the symbol such as "Meter symbol = DC".

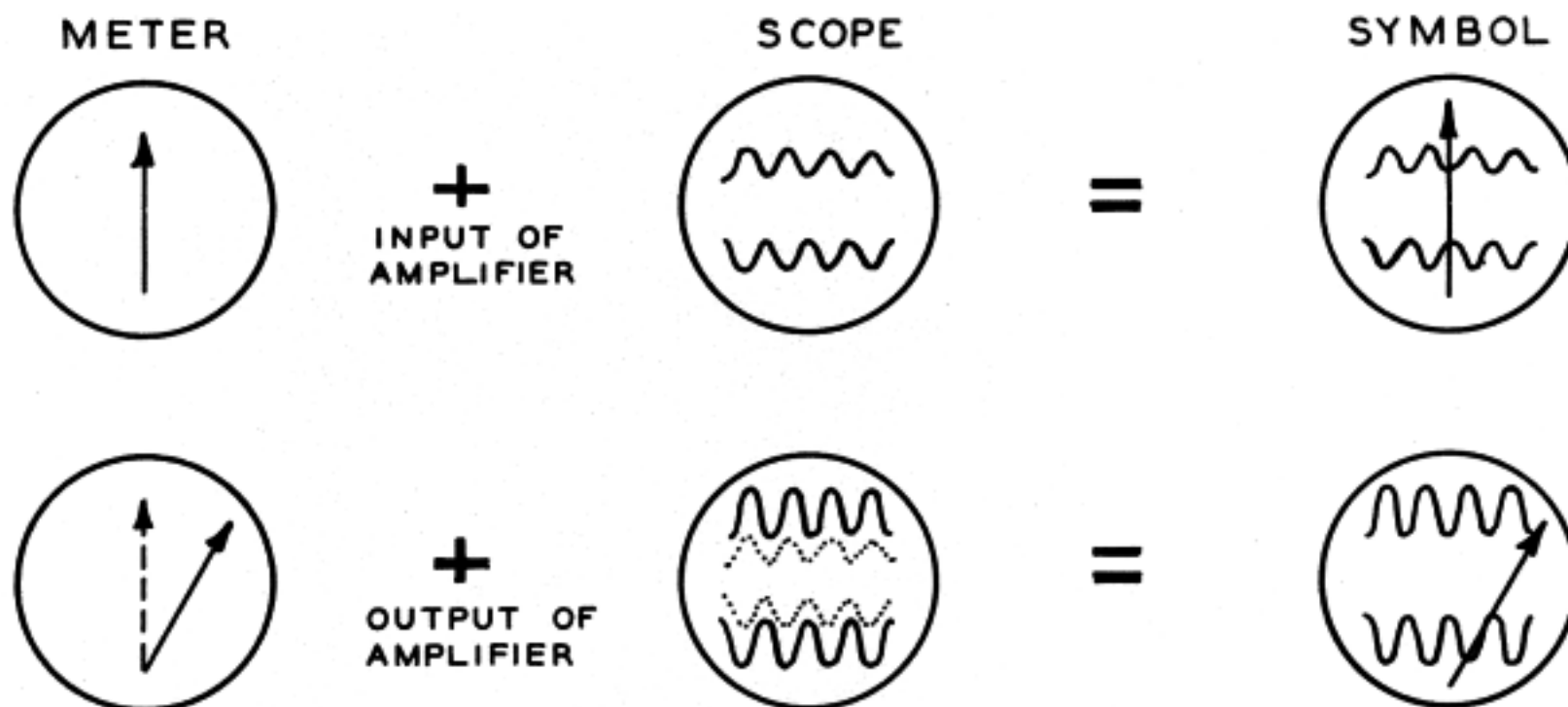

FIG.5-EXPLANATION OF OSCILLOGRAMS AND METER DEFLECTIONS USED IN THIS DISCUSSION.

The point by point description of this routine will describe some variations which could not be effectively illustrated in the block diagram of Fig.6. The letters (A,B,C, etc.) refer to the respective positions of the probes as indicated on the superheterodyne diagram shown in Fig. 6.

(A, B, C.) - With the exception of the tubes, the power supply is a common source of trouble and it is wise to see that it is producing the proper voltages before checking the signal circuits. As to whether A, B, or C should come first depends upon the conditions of the receiver. If the receiver has excessive hum or low volume, point "A" will indicate the output and general condition of the power supply. More details will be given later concerning the various results to be expected with different rectifier and filter systems. It should also be remembered that the VEDOLYZER contains a multimeter for measurement of the a-c or d-c voltages in the power supply. For confirmation of short or open circuits, the ohmmeter is at the operator's disposal. Of course, the receiver's Power Switch should be turned off before ohmmeter measurements are made.

(D) - Turn "FUNCTION SELECTOR" to "WAVEMETER" position (Band "C" for 1000kc) and tune in signal. With the output of the signal generator connected to the antenna terminals of the receiver, adjust the signal supply to about 1/4 inch deflection on the cathode ray tube screen. This establishes a reference voltage and also shows the condition of the supply signal. This is also illustrated by point (1) of Fig.7.

(E) - As we progress to point E with the R.F. probe, the amplification of the R.F. stage should show an increase on the meter of the VEDOLYZER as well as the scope which indicates a gain. This should be checked at a frequency near the low end of the broadcast bands as open or shorted r-f coils will indicate a decided loss if such a condition exists. (See points 2, 3, and 4, Fig.7)

NOTE: If meter deflects off scale or image disappears on screen of cathode ray tube retard "VERT.GAIN" control or use "MULTIPLIER" buttons until figure has the desired vertical amplitude. The "MULTIPLIER" should be used as a rough adjustment control and the "VERT.GAIN" as the vernier adjustment. It is advisable to keep the "VERT.GAIN" as close to 75% rotation as possible and attenuate with the "MULTIPLIER". This will prevent any possible overload to produce a false indication.

(F) - With the R.F. test probe connected to the input of the first i-f amplifier, we should obtain an oscillogram which shows the presence of two signals. Tune in the signal with the "WAVEMETER" and see if the i-f frequency can be determined. For example, if we think that it is possibly a 456kc signal at this point, set the "FUNCTION SELECTOR" switch to "B" and tune the dial in the vicinity of 456. If a peak is received, which confirms the presence of the i-f signal, proceed to point "G".

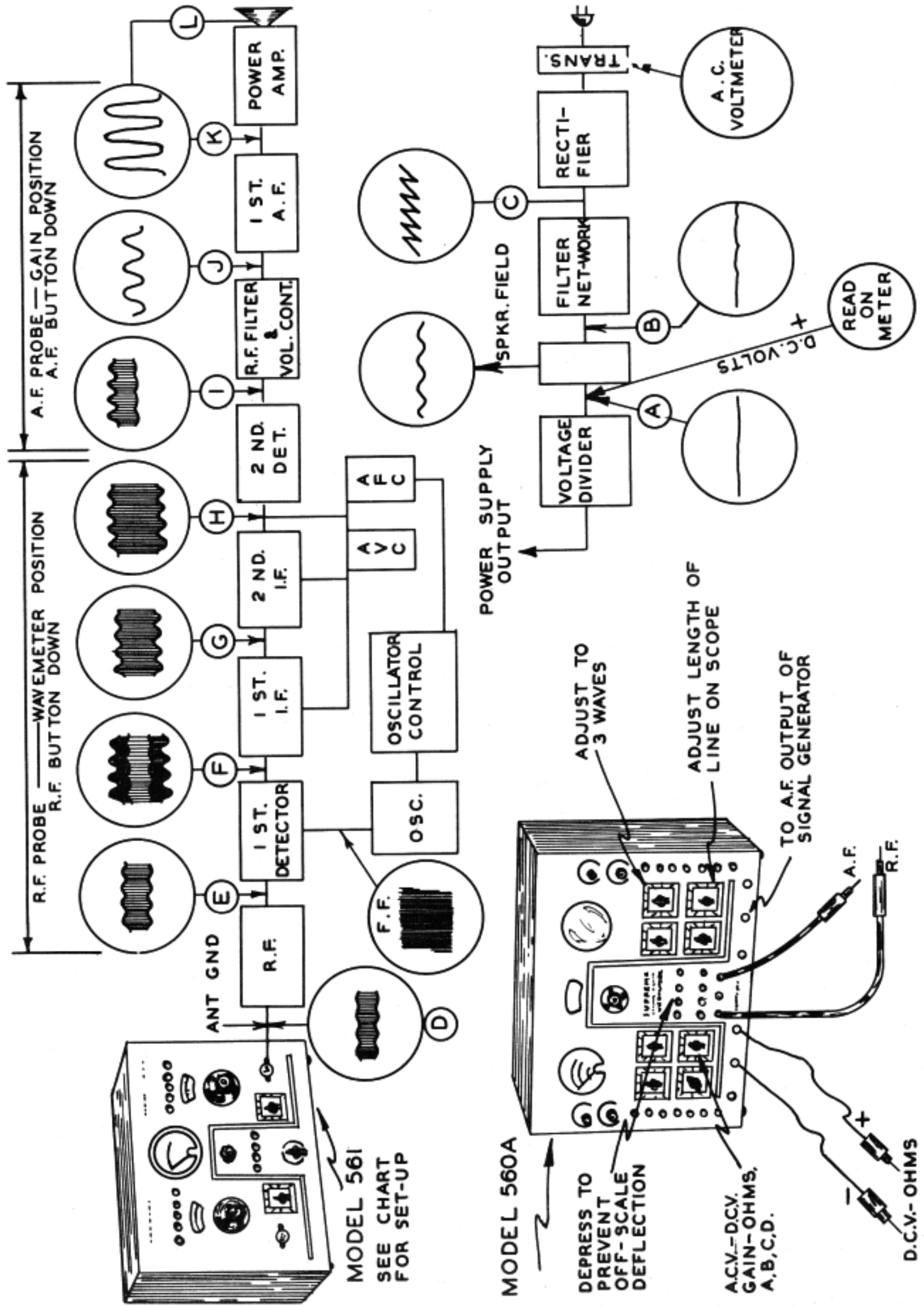
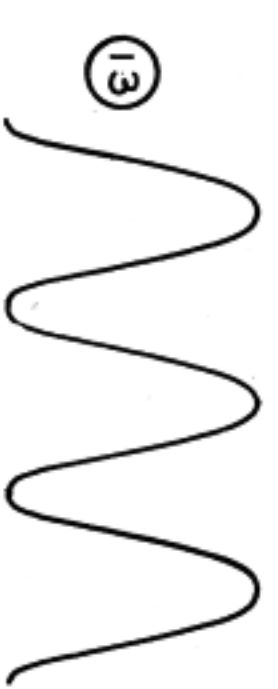
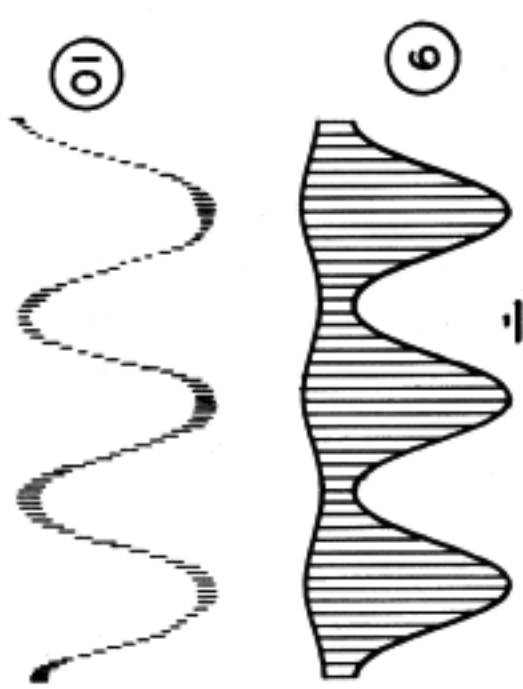
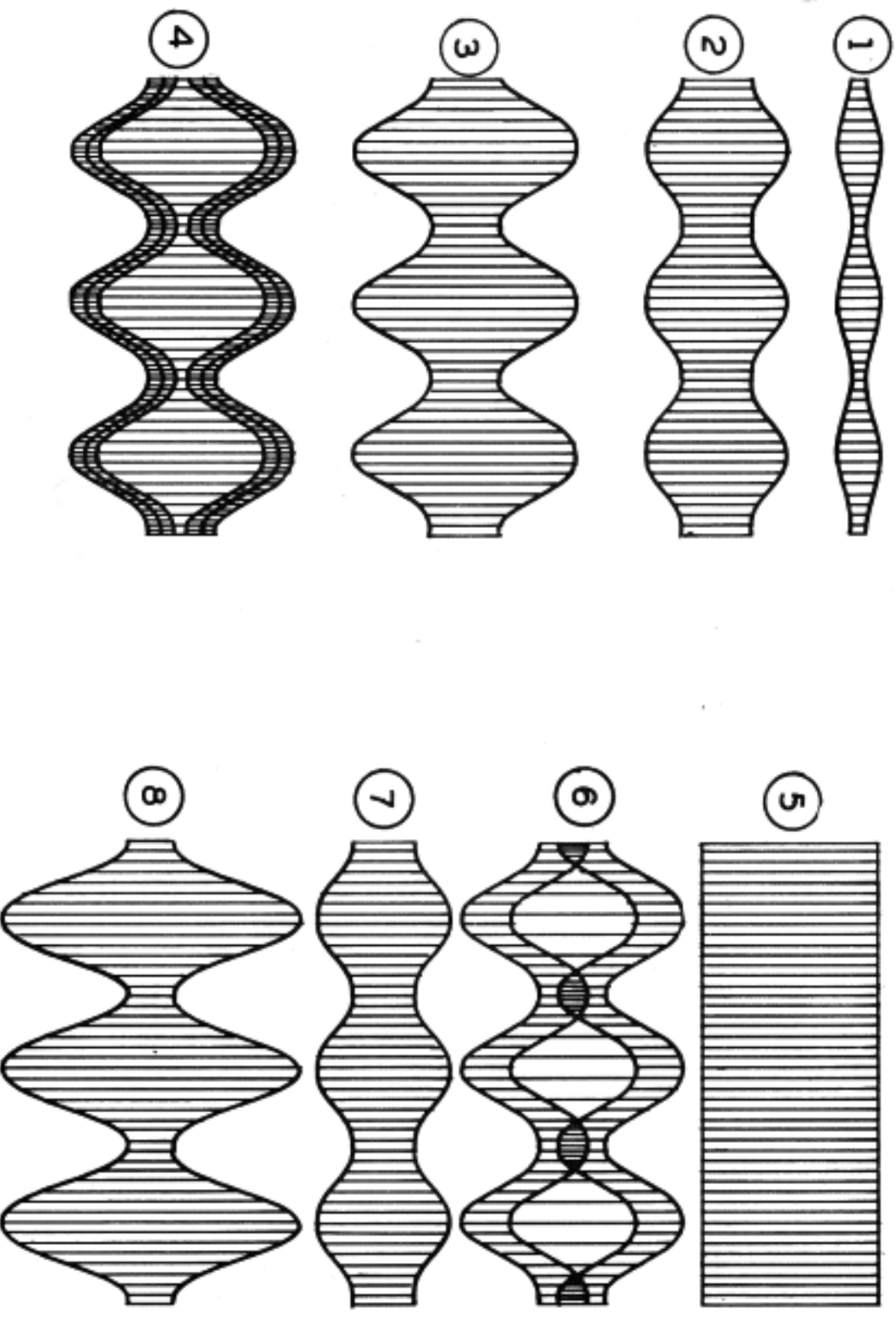
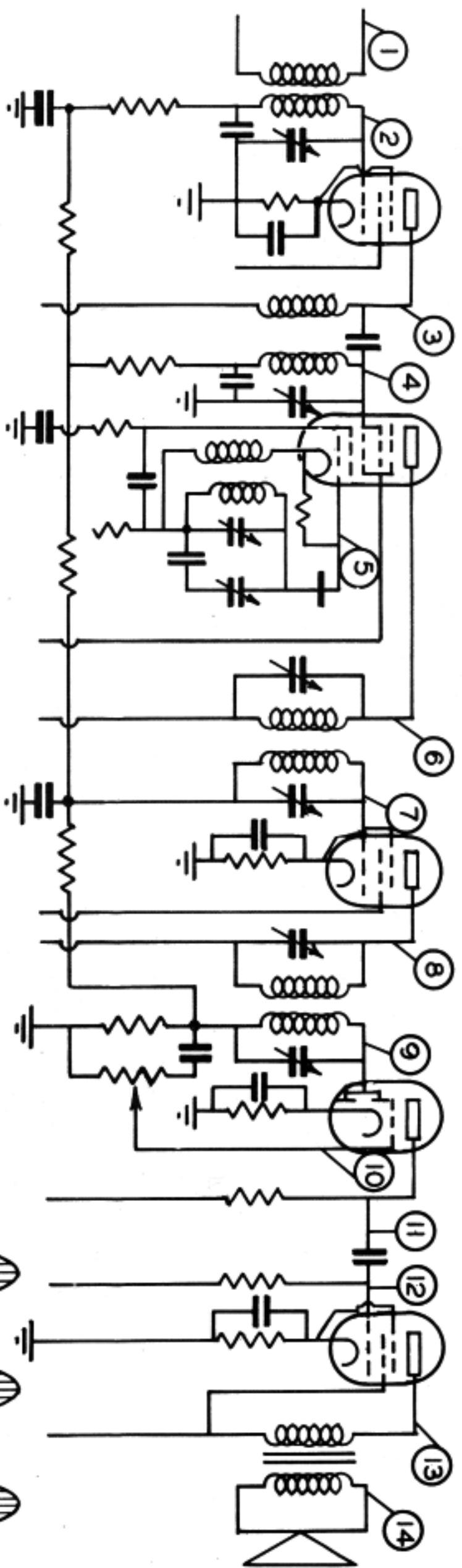

FIG. 6- BLOCK DIAGRAM OF A TYPICAL SUPERHETERODYNE RECEIVER WITH VEDOLYZER IN POSITION FOR SIGNAL TRACING.



11-SAME AS 10,BUT LARGER.
 12-EXACTLY LIKE 11.

13-SAME AS 10,BUT LARGER.
 14-SAME AS 13,BUT SMALLER

FIG.7-TYPICAL SUPERHETERODYNE SCHEMATIC SHOWING PRINCIPLE TESTING POINTS.

(G, H) - If the i-f signal does not seem to be present, check back on the oscillator at point F-F. The variable condenser of the receiver should be varied to observe the amplitude of the oscillator voltage over the entire band. If the signal is present and in good condition at G, check for amplification at point H. Fig.7, points 7-8, illustrate this part of the procedure also.

(I) - At this point, there is quite a contrast in the results obtained on the scope from that of the usual signal tracer. The VEDOLYZER shows the actual rectification of the i-f signal as seen on the waveform shown at '9', Fig.7, and 'I', Fig.6. The waveform of the signal at the rectifier or second detector in the receiver show the presence of the r-f signal, a common cause of distortion if it is not properly filtered out at 'J'. (Points 9-10 of Fig.7 show two stages of filtering the r-f from the audio component.)

(K) - If the filtering action was effective in the output of the detector, a clean audio signal will result at this point. The audio probe may be used here if desired or the testing may continue with the R.F. probe. If the filtering was not satisfactory, a modified form of point 10, Fig.7, will result. If the rectifying action is not correct or if the side of the r-f envelope which was rectified was distorted in one of the previous i-f stages, this will cause the rectified audio appearing across the diode-load to have a flat top on one-half cycle.

(L) - The voltage at the voice coil should be similar to that of the preceding stage with the exception of the amplitude, which is usually somewhat lower due the turns ratio of the output transformer.

THE TUNED RADIO FREQUENCY AMPLIFIER

In the previous routine we analyzed a superhetrodyne which was assumed to be operating properly. This procedure is general and may be applied to any system whose circuits perform the same functions and operate at the same frequencies as the sections of the superhetrodyne described above. The r-f and i-f stages in a superhetrodyne are somewhat like the stages of a tuned radio frequency (t-r-f) receiver and, consequently, there will be a similarity in the general testing procedure. The t-r-f circuit was at one time a very popular type with radio manufacturers and there are still a great many in use today.

To locate a defective part in a radio receiver, the usual method is to determine the faulty stage by the general routine and then check the individual components for the cause.

A very valuable application of the VEDOLYZER is checking condensers without disconnecting them from the receiver. Capacitors may be checked for leakage, shorts, opens or low capacity by touching the probe to the points indicated by the dotted lines in Fig.8. When condensers are of the proper capacity, they offer a low reactance to the a-c voltage (r-f, i-f or a-f) and a high resistance to the d-c voltage. This is illustrated in the three circular diagrams to the left of "Bypass condenser O.K." It will be noted that the DC Voltmeter indicates the normal d-c potential and the RF meter and scope show the absence of the a-c voltage. When the condenser is open, the scope as well as a-c and d-c meter show deflections. Shorted condensers show no deflection on the scope or meter.

Fig.8 shows the tuning and detector sections of a typical t-r-f circuit. Connect the cable of the signal generator to the antenna and ground post of the receiver and the testing starts with point A. The VEDOLYZER is set up as a signal tracer (See Fig. 5) and points A, B and C checked in order with the r-f probe only. The "FUNCTION SELECTOR" should be used in "WAVEMETER" position (A,B,C,D) with the dial set to frequency of the generator. (The ground wire of the VEDOLYZER should be connected to the chassis of the receiver.)

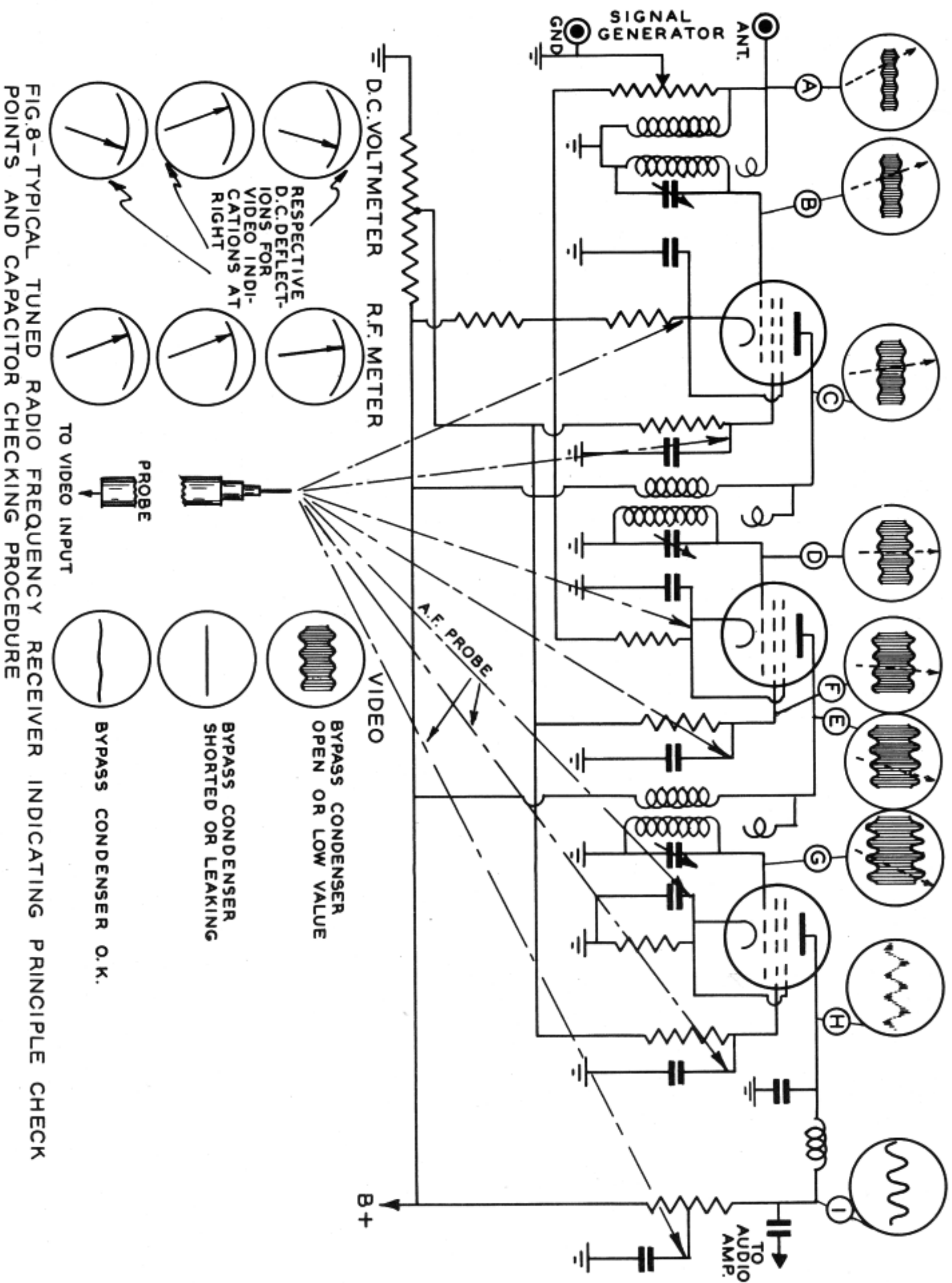

FIG. 8-TYPICAL TUNED RADIO FREQUENCY RECEIVER INDICATING PRINCIPLE CHECK POINTS AND CAPACITOR CHECKING PROCEDURE

The following steps indicate some of the possible abnormal effects and suggestions as to what could produce such conditions.

(A) - No Signal: Generator producing signal? Continuity from antenna to Point A? Position of Volume Control? -- Low Signal: Shorted Volume Control?

(B) - (Meter-scope should indicate gain) No Signal or loss in gain: Circuit in tune with generator frequency? Shorted condenser plates? -- Low Signal or loss in gain: Circuit in tune? Shorted condenser plates or coil terminals? Open coil? Shorted grid in tube?

(C) - (Meter-scope should indicate large increase) No Signal: Plate, screen and control grid voltage normal? Bypass condenser shorted or open? Tube Filaments? (Measure voltage at socket contact). Tube Emission? (Check on tube tester). -- Low Signal: Operating voltage? Type of waveform? Shorted turns in coil? Leaking or low value bypass condenser?

(D,E,F,and G) - D,E, and G same as A,B,C respectively. F indicates open screen grid condenser.

(H) - (Should indicate rectified signal) No Detection: Check tube and operating potentials.

(I) - (Should be almost pure sine wave) Distortion and lower than Point H: Open choke coil.--Distortion and approximately same amplitude as H: Check for open condenser. Check bias voltage on tube.

ANALYSIS OF RECEIVER BY CIRCUITS

The block diagram of Fig. 6 gives the general checking procedure for the common type of superhetrodyne circuit. This section will be devoted to special sections of a superhetrodyne and variations in receiver circuits which require individual tests. This will include AVC Detectors, Oscillators, AFC, Visual Alignment and Intermittents.

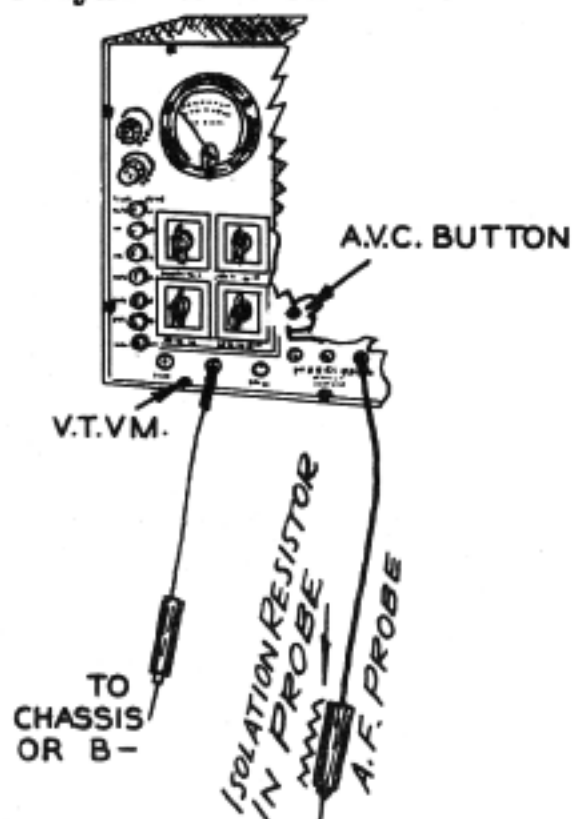

FIG.9-THE VEDOLYZER IN POSITION FOR CHECKING A.V.C. VOLTAGE.

Heretofore, we have used the VEDOLYZER only as a signal tracer with the R.F. probe. Since some of the above mentioned sections will require some changes in the probes and controls, it will be proper to examine the functions of the VEDOLYZER with respect to the application.

THE MEASUREMENT OF AVC VOLTAGE

To measure the automatic volume control voltage with the VEDOLYZER, use the set-up shown in Fig. 9. Any leads which are attached to the "GND" of the VEDOLYZER should be removed and a lead connected from the "V.T.V.M." positive terminal or pin jack to the chassis of the receiver. Depress the "A.V.C." button with the "FUNCTION SELECTOR" switch in "DCV" position. Now select a suitable range (usually about 20 volts) on the left hand pushbuttons and check the voltages at the points shown in Fig. 10, using the "A.F." probe. By tuning the signal in and out of resonance the automatic volume control action may be observed on the meter. When the receiver is tuned to some frequency other than that of the signal generator, the normal operating or static voltage will be noted. When the signal is tuned in, the voltage on the grids of the amplifier tubes will be considerably higher than the static voltage.

CHECKING THE POWER SUPPLY OF A RADIO RECEIVER

The power supply is common to all of the circuits of a receiver which uses the vacuum tube and, as a rule, many causes for radio failure originate in this particular section.

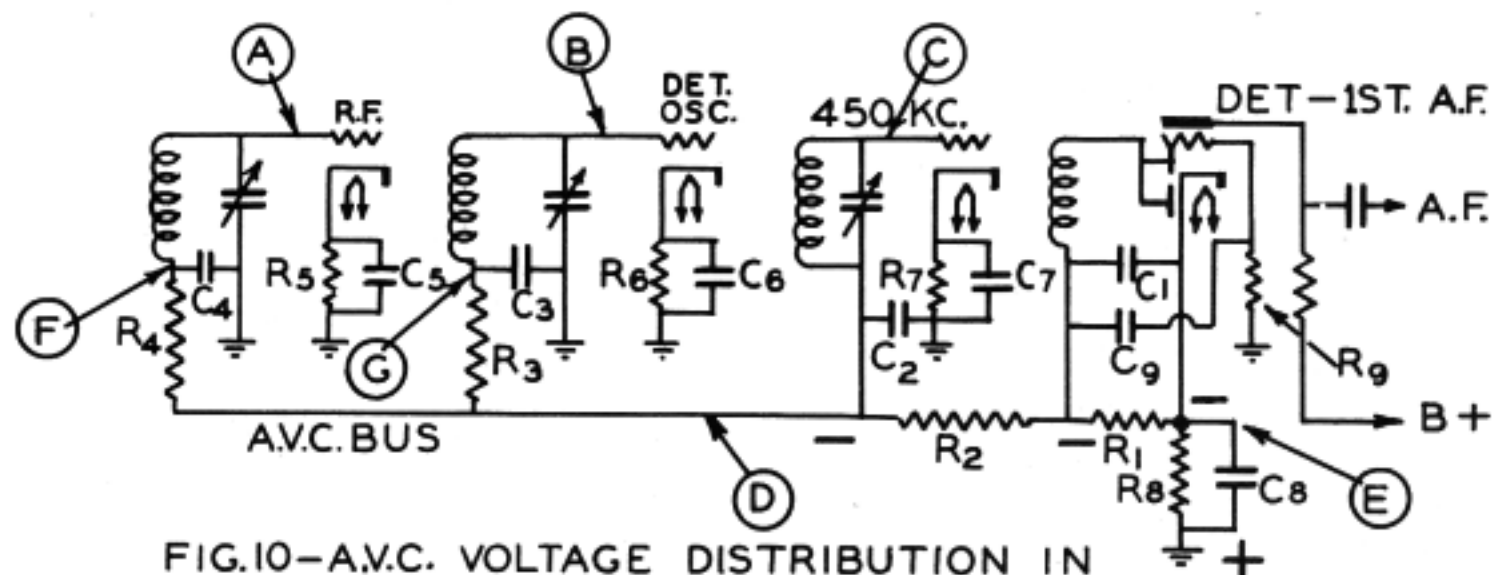

FIG.10-A.V.C. VOLTAGE DISTRIBUTION IN TYPICAL SUPERHETERODYNE.

The type of power supply depends upon the location in which the receiver is used and also the quality of the instrument. In sections where electric power is available, the AC and AC-DC sets will be found in the majority. In rural sections which do not have electrification, the battery type of receiver will be found. The variation in quality is represented by the small AC-DC compacts using an inexpensive half-wave system and the better grade of receivers using the full-wave system with a transformer. These small inexpensive receivers are found in large numbers due to the cost and portability. Some localities have a direct current supply, thus making a market for a DC receiver. The sets which are built for use in the d-c districts will usually be of standard quality and the filter system is designed to remove most of the commutator ripple caused by the d-c generator. Since there are several popular types of power supplies, it will be necessary to discuss each one separately in order to illustrate the defects as indicated with the VEDOLYZER.

SETTING UP THE VEDOLYZER FOR CHECKING THE POWER SUPPLY

Since the a-f section represents amplifiers in a regular oscillograph, this section of the VEDOLYZER will be used in the following discussion.

Connect the "A.F." probe to the "A.F." socket and push the "A.F." button. The multimeter section of the VEDOLYZER should be set up for d-c volts and regular test leads connected to the voltmeter terminals. (See the VEDOLYZER AS A MULTIMETER, Fig. 2). The sweep oscillator on the VEDOLYZER should be adjusted to one wave with line voltage applied to the probe.

CHECKING "A", "B" AND "C" BATTERIES

In order to determine the condition of any type of radio battery, the unit must be checked under the same load conditions it will have when connected to a receiver.

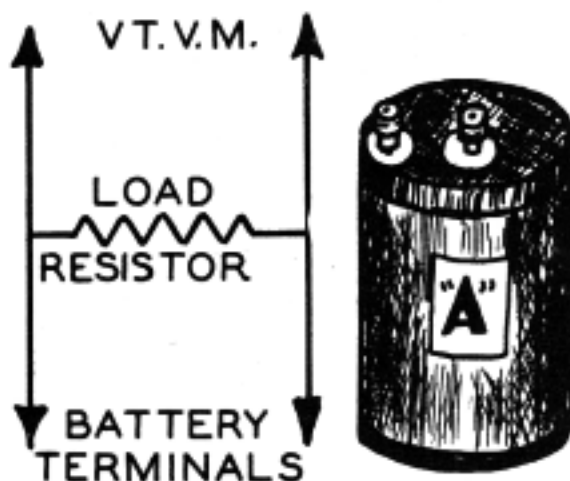

The battery or cell under test should be connected to the receiver or equivalent load and the voltage of each section measured by the d-c voltmeter of the VEDOLYZER. The voltmeter on the VEDOLYZER draws practically no current, and consequently, would not indicate the condition of the battery unless a definite load current is drawn from the battery under test. The correct load for the "A" battery may be determined

FIG.11-CHECKING BATTERIES WITH THE VEDOLYZER.

by adding the total amount of current drawn by the filaments and dividing into the no-load voltage. Load resistor = rated battery voltage divided by the filament current. The "B" and "C" batteries are checked the same as the "A" batteries with the exception of the load resistor which is determined by the amount of anode (plate, screen, etc.) current drawn by the tube. Average drain for portable radio approximately 10 millamperes.

CHECKING THE FULL WAVE RECTIFIER AND THE BRUTE FORCE FILTER

The conventional full wave rectifier circuit shown in Fig. 12 is very popular among radio manufacturers for receivers to be sold in districts which have alternating current. One of the chief advantages of this system is that the full wave rectifier produces a ripple voltage of twice the frequency of the line voltage, which simplifies the filter network. This type of circuit usually consists of a power transformer, thermionic rectifier and a low pass filter system.

In general, the results to be expected from a such a power supply would be a d-c voltage high enough to excite the various anodes and yet have a minimum a-c component. The ideal situation would be to have a "no-hum" output such as that produced by batteries. Each filter section reduces the a-c component and some minimum hum level must be established with respect to the number of filter sections. This information may be obtained by checking some of the popular models of receivers in your particular territory and recording this data for future use. If you do not have the data on a particular model, the following notes should prove of some value.

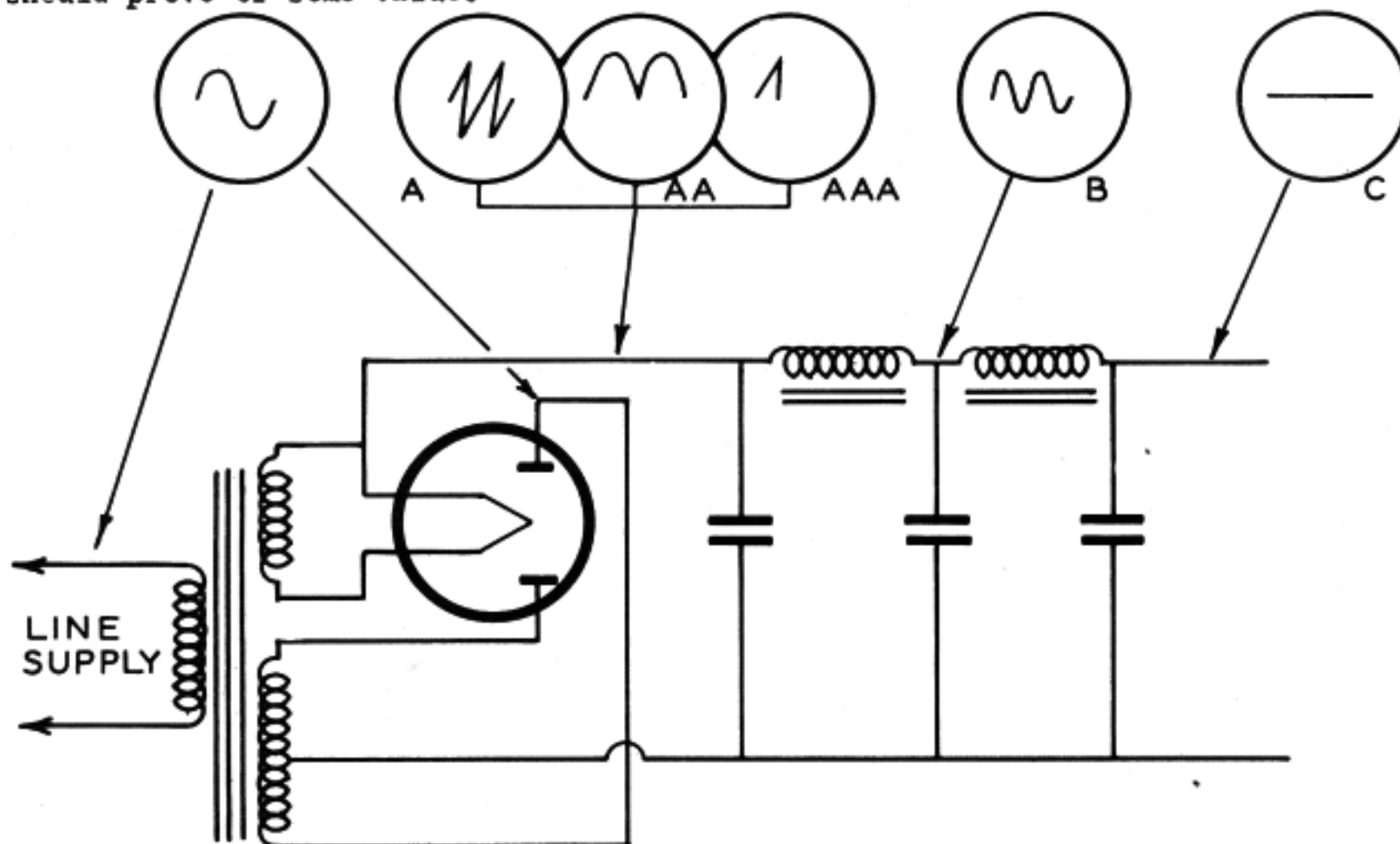

FIG.12: TYPICAL FULL-WAVE RECTIFIER STAGE WITH CONDENSER INPUT FILTER AND TWO CHOKE-CONDENSER SECTIONS.

The amount of hum present at the output of a power supply depends upon resonant frequency of the low pass filter and the ability of the inductors to maintain their respective values with variations in the output load. A well designed filter section in the average receiver will cause a decrease in the a-c component to about one-thirtieth to one-fortieth ($1/30$ to $1/40$) between the rectifier output and the second filter section.

Fig. 12 shows a typical full-wave rectifier circuit with a brute force filter system. For the sake of comparison we have shown two complete filter sections, although many

receivers use only one. In sets which utilize the dynamic speaker one of the filter chokes will usually be the speaker field coil.

Perhaps one of the most common troubles in a power supply is the breaking down of the filter condensers, causing a reduced voltage at the output of the power system. This should be checked first by the usual voltmeter method starting at point "C" and then if low voltage appears at this point, proceed toward the output of the rectifier, power transformer, etc.

If the trouble does not appear to be caused by a low voltage and the hum level appears to be above normal, the following check should prove helpful in locating the defective part. Set the VEDOLYZER up as an untuned signal tracer ("FUNCTION SELECTOR" in "GAIN" position) and with the "A.F." probe proceed as follows:

Connect a lead from "GND" to chassis of receiver and with "A.F." probe start at the output of the rectifier or filter input. Point "A" represents the results to be expected if the condenser is effective on a condenser input filter system. If Oscillogram AA appears on the screen when checking a condenser input system, the effect is the same as a choke input system which represents a low capacity input condenser.

If the system is a choke input filter, AA represents the correct results and A would represent a shorted choke coil. The frequency in the choke input or condenser should be equal to twice the frequency of the line supply. This will be represented by two waves on the scope. If only one wave appears, such as represented by Fig. AAA, the voltage should be checked at the plates of the rectifier for a possible open secondary or shorted tube. At point "B" we should find a reduction in the a-c voltage of about 30 to 1 and the voltage will be more of a sinusoidal form instead of the usual saw-tooth wave shape.

Proceed to point "C"; the amplitude of the a-c component should be very low or negligible, depending on the number of filter sections and the load.

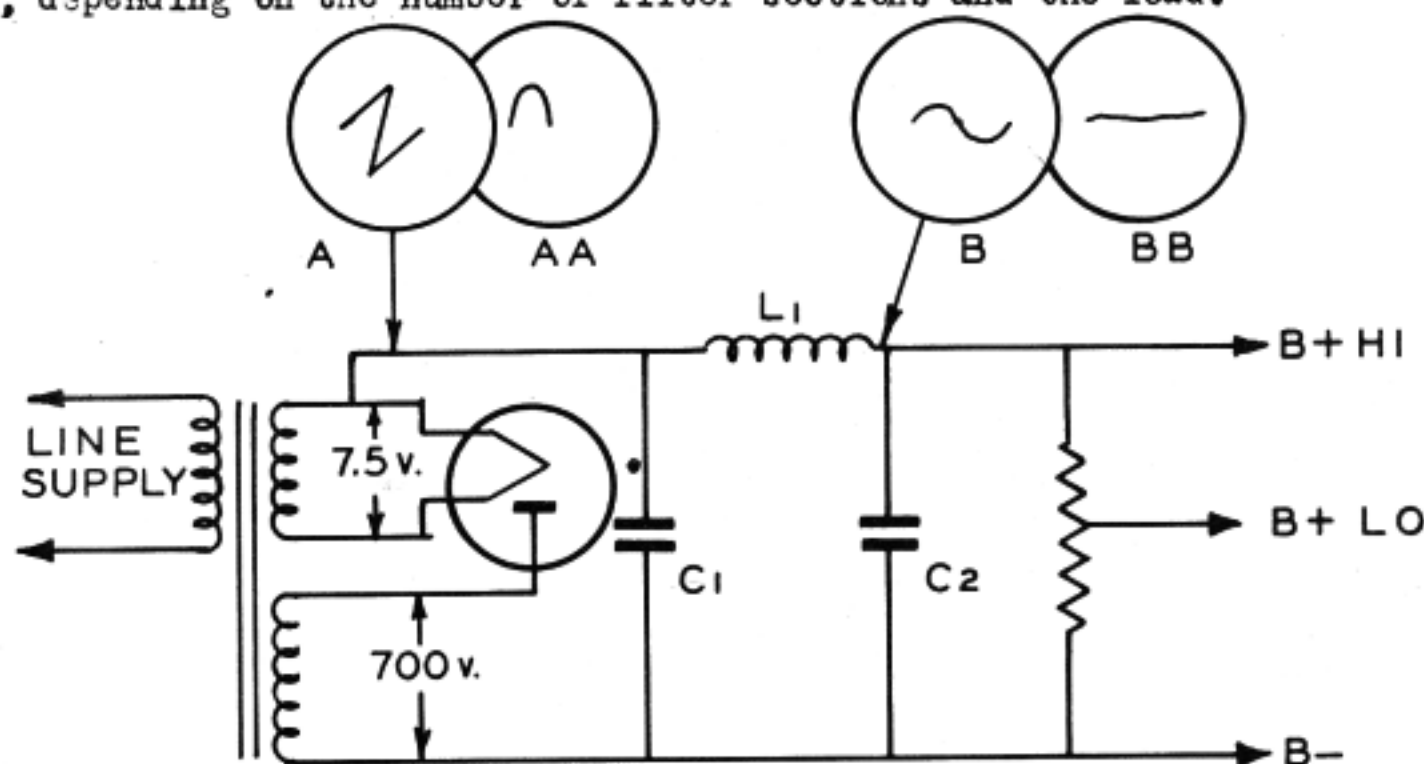

FIG.13-TYPICAL HALF-WAVE RECTIFIER CIRCUIT USING CONDENSER INPUT-FILTER.

THE HALF-WAVE RECTIFIER AND BRUTE FORCE FILTER

The half-wave rectifier has come into prominence in the past few years due to the introduction of the small compact receivers and AC-DC sets. Frequently, in very old sets we will find the half-wave rectifier and sometimes we run upon the full-wave circuit using a double half-wave circuit. The half-wave rectifier using a transformer is illustrated in Fig. 13.

The transformerless AC-DC receivers use the half-wave rectifier circuits. The anode voltage supply is obtained directly from the line supplying a d-c potential very close to that of the line when used with a condenser input filter system. The variation in this circuit from that of Fig. 12 will be the absence of the transformer and an indirect heated cathode rectifier. One side of the line will form the negative return while the other side will be connected to the plate of the rectifier. As a rule, these small sets have the filaments of all of the tubes connected in series.

The results obtained with the half-wave circuit will be exactly the same as the full-wave rectifier when one side of the high voltage winding is open. This is represented by "A" in Fig. 13 and "AAA" in Fig. 12. Oscillogram "AA" of Fig. 13 illustrates the results to be expected when the first filter condenser is open or of low value or when the filter circuit is of the choke input type. The next points "B" and "BB" indicate hum and no-hum respectively.

THE RECTIFIER-VOLTAGE DOUBLER CIRCUIT

The voltage doubler rectifier circuit has also become popular in the past few years due to the increased demand for an inexpensive compact receiver. The chief advantage of this type of circuit is the ability of the circuit to produce a voltage equal to approximately twice that of the applied a-c voltage without the use of a step-up transformer.

After looking at the circuit of the conventional rectifier systems which we have analyzed previously, the voltage doubler circuit in Fig. 14 has a complicated appearance. The diagram will be simplified somewhat if we draw it in the form of a regular half section

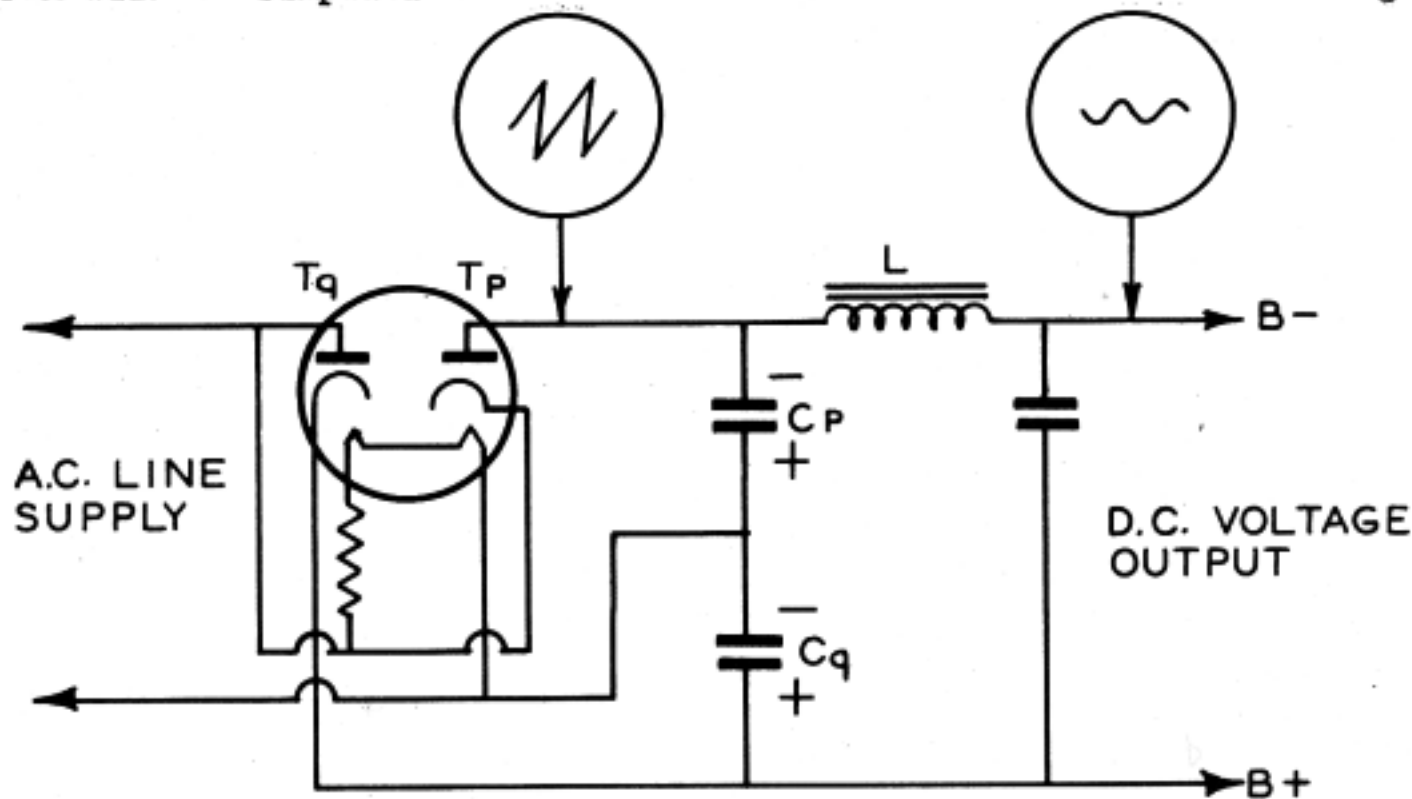

FIG.14-TYPICAL VOLTAGE-DOUBLER CIRCUIT.

of a bridge rectifier with the other half composed of two capacitors as in Fig. 15. When the plate voltage is positive with respect to cathode on T_q , condenser C_q charges to approximately the line voltage. On the remaining part of the cycle the voltage is rectified through T_p and charges C_p . In other words, C_p and C_q are charged alternately and discharged into the load in series. The wave form at the output of the rectifier will be identical to that of the full-wave rectifier with a condenser input filter. The voltage output depends upon the capacity of C_q and C_p , the d-c load, and the condition of the rectifier tube. The voltage output load current curve is practically a straight line using condensers of from 20 to 30 microfarads each. Roughly the no-load voltage should be about 2.3 times the input a-c voltage and the full load voltage will be approximately 1.8 times the a-c input voltage. Of course, these voltage measurements must be made at the output of the rectifier and will be greater than measurements at the end of the filter section due to the drop across the filter choke.

In most of the small compact receivers the half wave rectifier is used and the a-c circuit is very similar to that of the voltage doubler, i.e., using no step-up transformer.

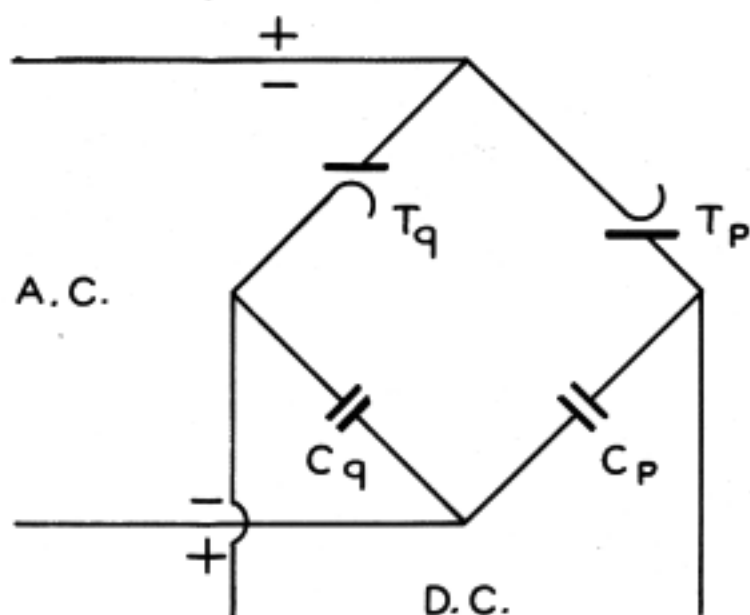

FIG.15 _SIMPLIFIED DRAWING OF FIG.14.

receiver should be located and the "GND" of the VEDOLYZER connected to this point.

Due to the inexpensive construction, the filter circuits of both the voltage doubler and the half wave rectifier have about the same action on the screen of the cathode ray oscillograph. The chief difference will be the frequency of the d-c impulses which is twice that of the line in the case of the voltage doubler and equal to that of the line in the case of the half wave rectifier.

NOTE: In some cases, especially on the AC-DC type of receiver, the chassis is not the ground return or "B-" When circuits of this type are encountered, the ground return of the receiver should be located and the "GND" of the VEDOLYZER connected to this point.

CHECKING POWER SUPPLIES UTILIZING VIBRATOR UNITS

The popularity of the vibrator in automobile power supply units has widened its application to household receivers and aviation radios. When this device was first introduced in automobile receivers, it was built into the set, thus making replacements difficult due to the mechanical arrangement of this section. The time required to obtain an exact duplicate replacement part brought about an attempt to make the repairs in the service shop without the aid of the special equipment which was used in the manufacture of the device.

Since the introduction of the vibrator, this handicap has been removed by making the part a plug-in device, thus facilitating replacements. The cathode ray oscillograph may be used to check the overall output of the vibrator. However, radio engineers do not recommend its use in checking components of the vibrator. This is one of few parts in a radio receiver that presents more mechanical trouble than it has electrical failures. Many servicemen have come to the conclusion that it is far more economical and practical to replace the vibrator rather than try to localize the trouble and attempt to repair it.

CHECKING OSCILLATORS AND CONVERTERS

Shortly after the advent of the superheterodyne came the multipurpose tube which added confusion as to the operation of the circuit. The first detector and oscillator circuits are often referred to as converters, mixers, translators and, thus, some servicemen are in the dark as to what really happens. The cathode ray tube indicates the changes, step by step, and has shown that there is actually a rectifier circuit preceding the intermediate frequency stage and should be treated as a detector.

Though fewer sets use a separate tube as the detector, we find many cases of a separate oscillator, particularly in the higher priced receivers. This is illustrated in Fig. 16.

Points A and B indicate the gain and continuity of the voltage across the r-f transformer which was explained in the analysis of the tuned radio frequency amplifier. Here we temporarily omit points E, F and G and check point C. C illustrates the third voltage or oscillator in the intermediate frequency waveform. In the oscillogram D, the oscillator voltage will indicate its presence when tuned in on the wavemeter. If this voltage is not present, check point E for normal amplitude, F for low oscillator voltage and G for intermittent operation over the tuning range. H, I and K show the scope and meter

indications for checking the bypass condensers. The meter deflections indicate the d-c voltage and the oscillogram indicates the r-f voltage. Point J shows the presence of the oscillator voltage at the tubes.

In order to save space in receivers, frequently a multipurpose tube is employed as the oscillator and converter. This type of circuit is represented in Fig. 17, and the progression is similar to that of the former circuit employing the separate oscillator.

- (A) - Point A represents the R.F. input (usually antenna transformer).
- (B) - Point B indicates a gain due to the turns ratio and resonant effect of the secondary.
- (C) - Point C indicates the presence of the intermediate frequency (I.F.) signal.
- (D & E) - Points D and E show that the conversion was made with low amplitude or distortion respectively. If C represents a good clean signal proceed to point F, if not, check at

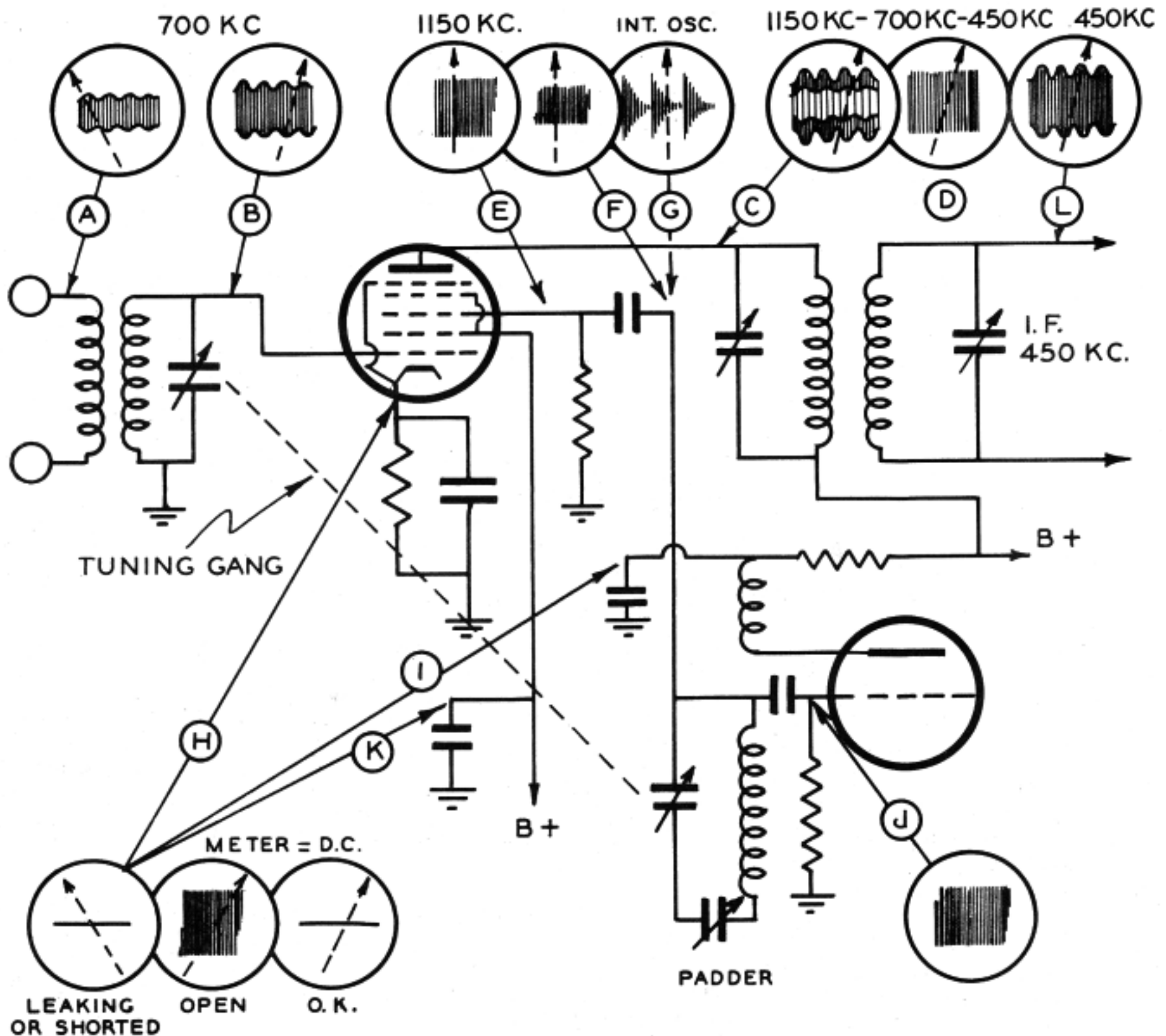

FIG.16—TYPICAL CONVERTER SECTION USING SEPARATE OSCILLATOR AND 1ST. DETECTOR.

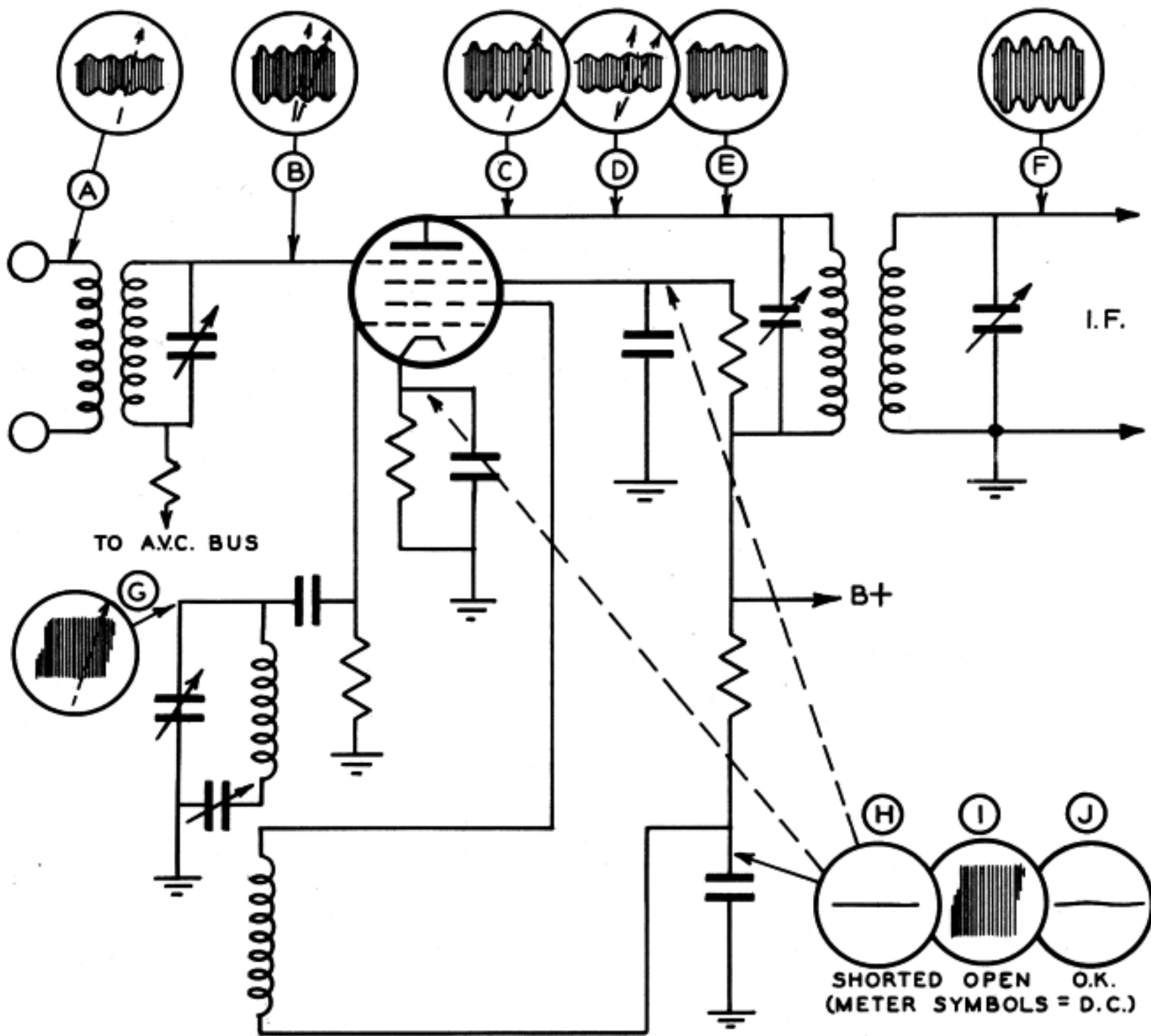

FIG.17—TYPICAL CONVERTER SECTION USING COMBINED OSCILLATOR AND 1ST. DETECTOR.

G for the voltage output of the oscillator. If the signal from the oscillator appears to be low or intermittent check the condensers as indicated by H, I and K. The arrows represent the respective d-c potentials and the presence of the radio frequency signal.

CHECKING INTERMITTENTS WITH THE VEDOLYZER

One of the most difficult cases of trouble to be found in a radio is the "intermittent". The very nature of the word indicates why this type of trouble in a radio receiver can cause hours of worry and frequently a financial loss on the service job. As long as the set is operating normally then evidently all of the components are temporarily O.K. and thus would not reveal the defect. Sometimes we can disturb a circuit and make the trouble appear, but more often we have to wait patiently for the operation of the receiver to become abnormal.

The time required to trace down and eliminate the "intermittent" has been greatly decreased by the dynamic analyzer. The VEDOLYZER set up for this type of analysis is shown in Fig. 18. All of the probes are used in order to monitor as many circuits as possible, thus making it easy to localize the trouble when the effect of the faulty part appears.

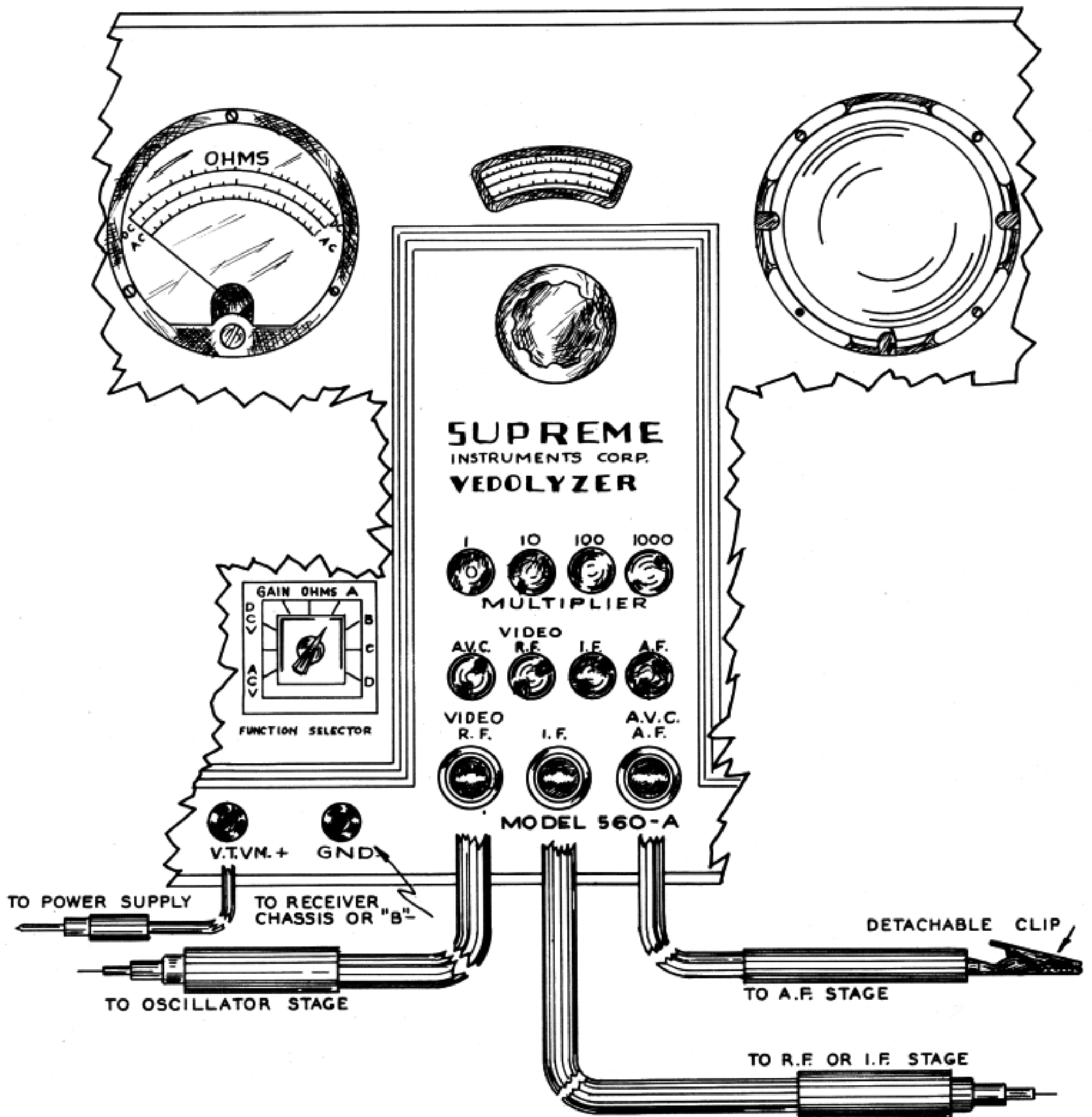

FIG.18—THE VEDOLYZER AS A SIGNAL MONITOR FOR CHECKING INTERMITTENTS.

The regular test lead should be connected from the "V.T.V.M.+" to the output of the power supply so that a failure at this point may be checked when the trouble appears. The various stages or sections of the receiver should be connected as indicated in Fig. 19. The procedure is as follows: Connect the "R.F." probe to the stage of the oscillator variable condenser. Place the "I.F." probe on the input of the "I.F." amplifier. The "A.F." probe should be connected to the output of the audio section. The wave shape of the pattern on the cathode ray oscillograph screen should be carefully observed and the amplitude carefully noted when each cable selector is depressed.

When the trouble appears, push buttons "R.F.", "I.F." and "A.F." consecutively and observe the scope. If the signal fails to appear upon the cathode ray screen then your trouble is between the place where the signal was present and where it was not. One should not neglect to observe the meter monitoring the power supply which may indicate

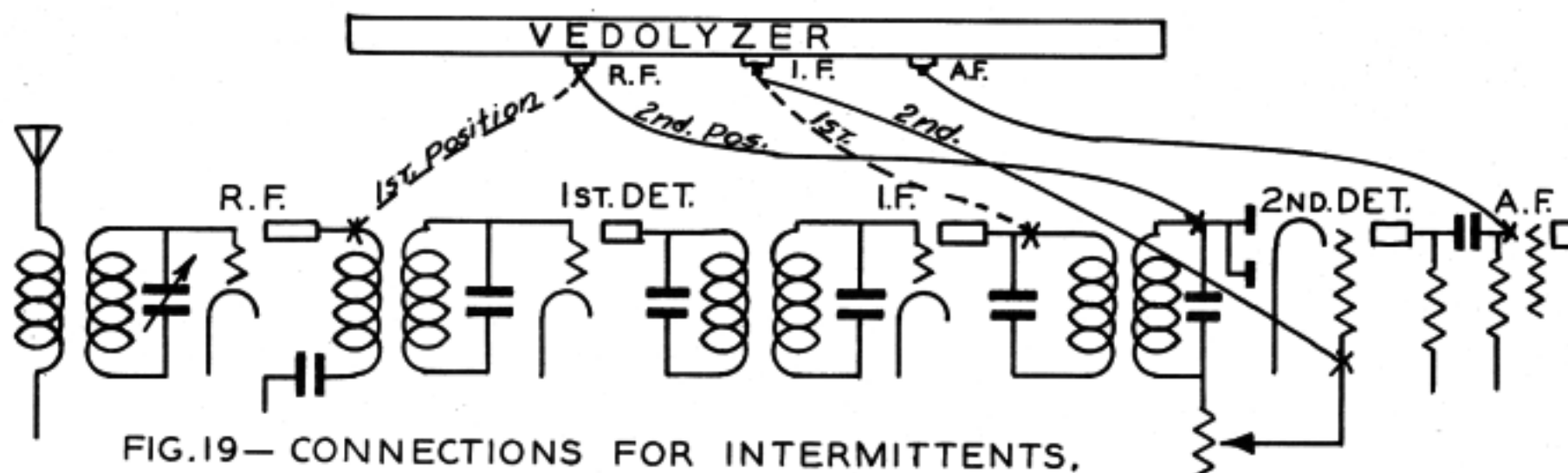

FIG.19— CONNECTIONS FOR INTERMITTENTS.

that the trouble is in this section. Furthermore, if you note that the trouble has appeared and the power supply is still producing the desired output, the "FUNCTION SELECTOR" switch may be rotated to "WAVEMETER" position and used in conjunction with the scope.

After the trouble has been placed in some particular section the rest is simple signal tracing. Frequently signal tracing will locate the intermittent as it indicates where the signal stopped or first distorted.

Let us take a particular case such as that illustrated in Fig. 19. The probes are attached to the defective receiver as indicated by the dotted lines. Now let's suppose the signal goes out, destroys, or reduces in volume. Pushing the "VIDEO" and "I.F." buttons indicates the signal is normal at these points. Upon pushing the "A.F." button we find no indication on the screen. Evidently, the trouble is between the connections of the "I.F." and "A.F." probes. Now to close in on this case of trouble, we place the probes as indicated by the solid lines and repeat the procedure when the set fails. No indication on the "A.F." probe with these connections and the trouble is either a defective tube or a bad coupling condenser between the two audio stages.

MAKING GAIN MEASUREMENTS WITH THE VEDOLYZER

In order to measure the gain of an A.F., R.F. or I.F. amplifier, the following procedure should be followed. With the function control of the VEDOLYZER set for "GAIN" and using the "R.F." probe on the input of the stage to be tested, rotate the "VERT.GAIN" until the meter indicates approximately one-half scale deflection. Observe the "MULTIPLIER" buttons and "VERTICAL GAIN" control. Next, place the probe on the output of the stage or stages to be checked and push the "MULTIPLIER" buttons and rotate the "VERT.GAIN" control until the former deflection of the meter is obtained. The gain is equal to the ratio of the first setting of the "VERT.GAIN" control and "MULTIPLIER", to the last setting or vice versa if there is a loss.

As an example, suppose that we place the "R.F." probe on the input of the first "I.F." stage in a superhetrodyne and obtain half-scale deflection by depressing the "1000" button with the "VERT.GAIN" control set at 50. At the input of the second, say that we have to depress the "100" button and rotate the "VERT.GAIN" control to 25. The gain is then represented by 50,000 (50 x 1,000) to 2500 (25 x 100) or 20 to 1.

CHECKING DEMODULATORS (DETECTORS) OF RECEIVERS

In order to extract the audio component from the signal for the previous I.F. or R.F. stage some form of rectification must be employed. The process of rectifying the

Radio Frequency signal and filtering out the high frequency current is called detection.

There are several types of detectors employed in performing this function and each has its particular properties as well as its effect upon the cathode ray tube screen.

Diode Detectors: This type of rectifier or detector is perhaps the most popular in modern receivers due to its ability to produce linear rectification. It may also be said that it is one of the most simple types of detectors as well as being one of the first types used in the commercial radio receiver.

Fig. 20A illustrates a typical diode detector circuit which you will observe looks similar to the half-wave rectifier shown in Fig. 13. The modulated signal on the secondary of the R.F. or I.F. transformer (C) is rectified by the tube T1 and the resulting audio component is developed across the diode load resistor at A. Filter C1 tends to reduce the high frequency to approach that of AA. The AVC voltage at "AVC BUS" and "B" should indicate a steady d-c potential regardless of the audio variation

Fig. 20B illustrates a diode detector and also an additional diode which is utilized for delayed AVC. The only difference between this type of circuit and the one discussed

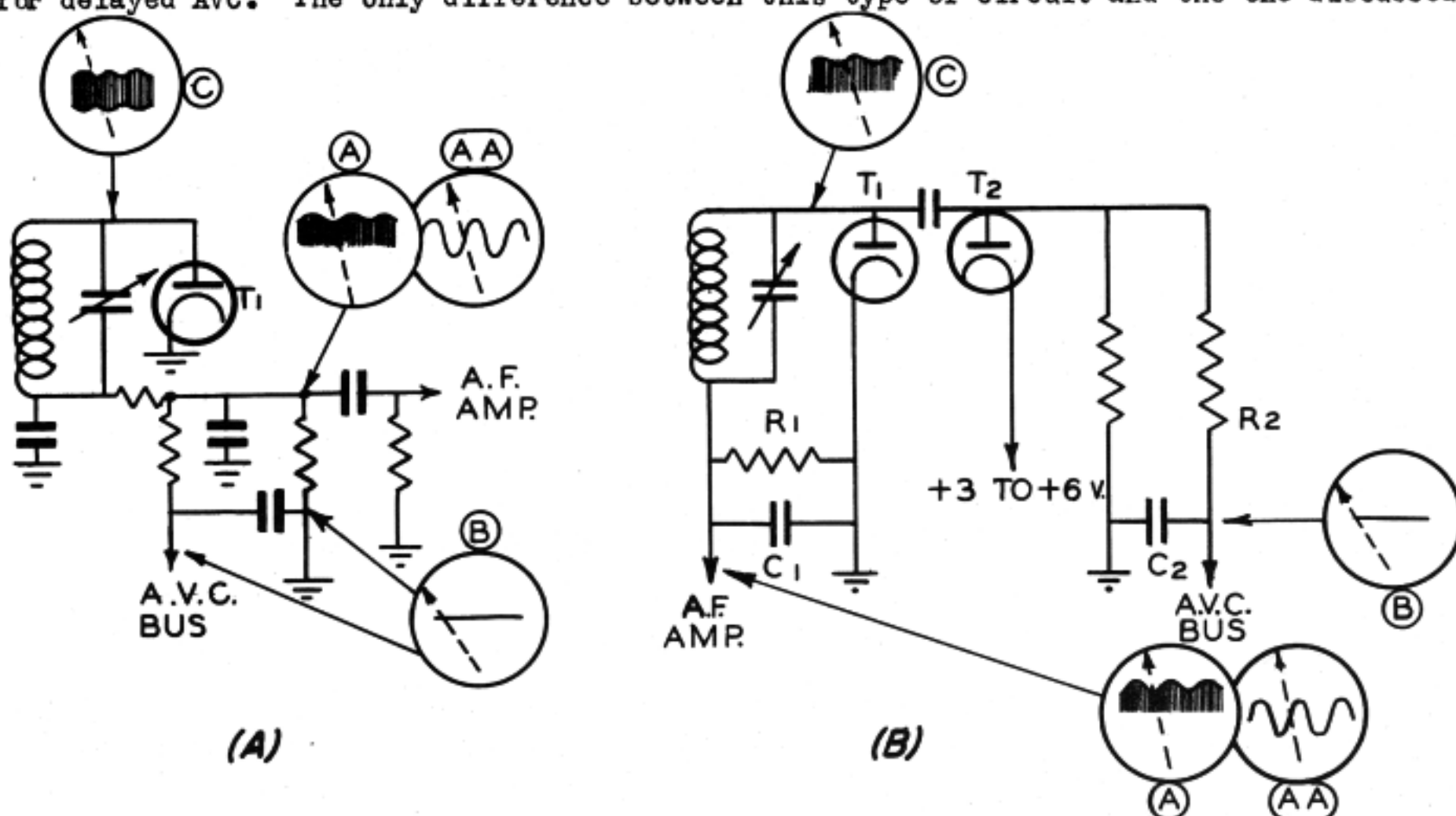

FIG.20-TYPICAL DIODE DETECTORS.(A) SHOWS DIODE DETECTOR WITH A.V.C. (B) SHOWS DUO-DIODE DETECTOR WITH DELAYED A.V.C.

previously is that a d-c compensating voltage is introduced in the AVC rectifying section to overcome the sudden biasing effect when a large r-f signal is present. The results on the scope are the same as in the case of the former AVC circuit and the oscillograms A, B and C indicate the respective points. The bias cell or supply providing the compensating voltage should be checked with the regular external d-c V.T.VM. T1 and T2 are usually included in a single envelope such as duo-diodes 6H6, etc.

Triode Detectors: When the tuned radio frequency receiver was at the height of its popularity, the triode detector was usually employed. This particular type of detector gives some amplification, however, we frequently find distortion at the output due to the non-linear rectifying characteristics. Fig. 21A illustrates a typical Grid leak detector and the results to be expected upon the cathode ray tube screen. Rectification takes place in the grid circuit similar to that in a diode detector as shown at B, C and D.

indicate the results in the plate circuit before and after it has passed through the RF filter choke (RFC). Fig. 21B illustrates what the operator should expect when checking a detector of the bias type.

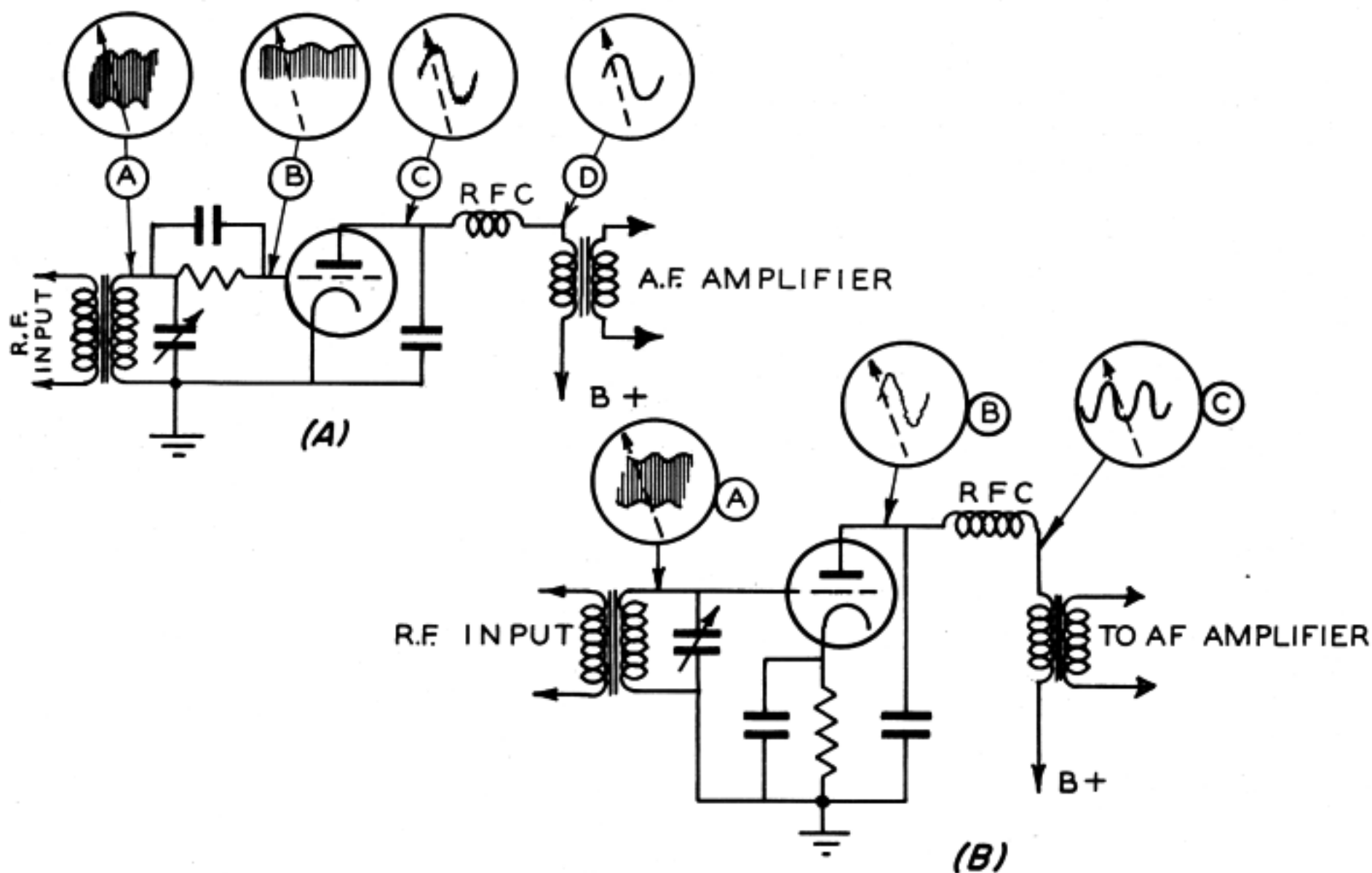

FIG.21-TYPICAL TRIODE DETECTORS. (A) IS GRID-LEAK TYPE, (B) IS BIASED DETECTOR TYPE.

CHECKING RECEIVERS WITH AFC CIRCUITS

Fig. 22A and Fig. 22B represent typical discriminator circuits employed to convert the resulting frequency variations voltage changes which are in turn applied to the grid of the oscillator control tube.

This is accomplished by using a duo-diode detector with signals of equal strength applied to the anodes of the tube when the oscillator of the receiver is tuned to the proper frequency. When there is a shift in frequency the voltages on the anodes of the plates of the rectifier are different and in turn produce a change in the voltage across the bleeder network R_p and R_q . The measurement at this point is exactly the same as described for AVC circuits and the RF voltage should be about at B and C.

Checking the Control Tube: The control tube is operated similar to that of an A.F. amplifier with special phasing circuit and may be checked by monitoring the oscillator with the VEDOLYZER as a wave meter and tuning the receiver slightly in and out of tune with the incoming signal..

CHECKING TUNING INDICATORS

In testing tuning indicator circuits, set the VEDOLYZER in position for signal tracing and check points A, B and C as shown in Fig. 24. A should indicate the presence of

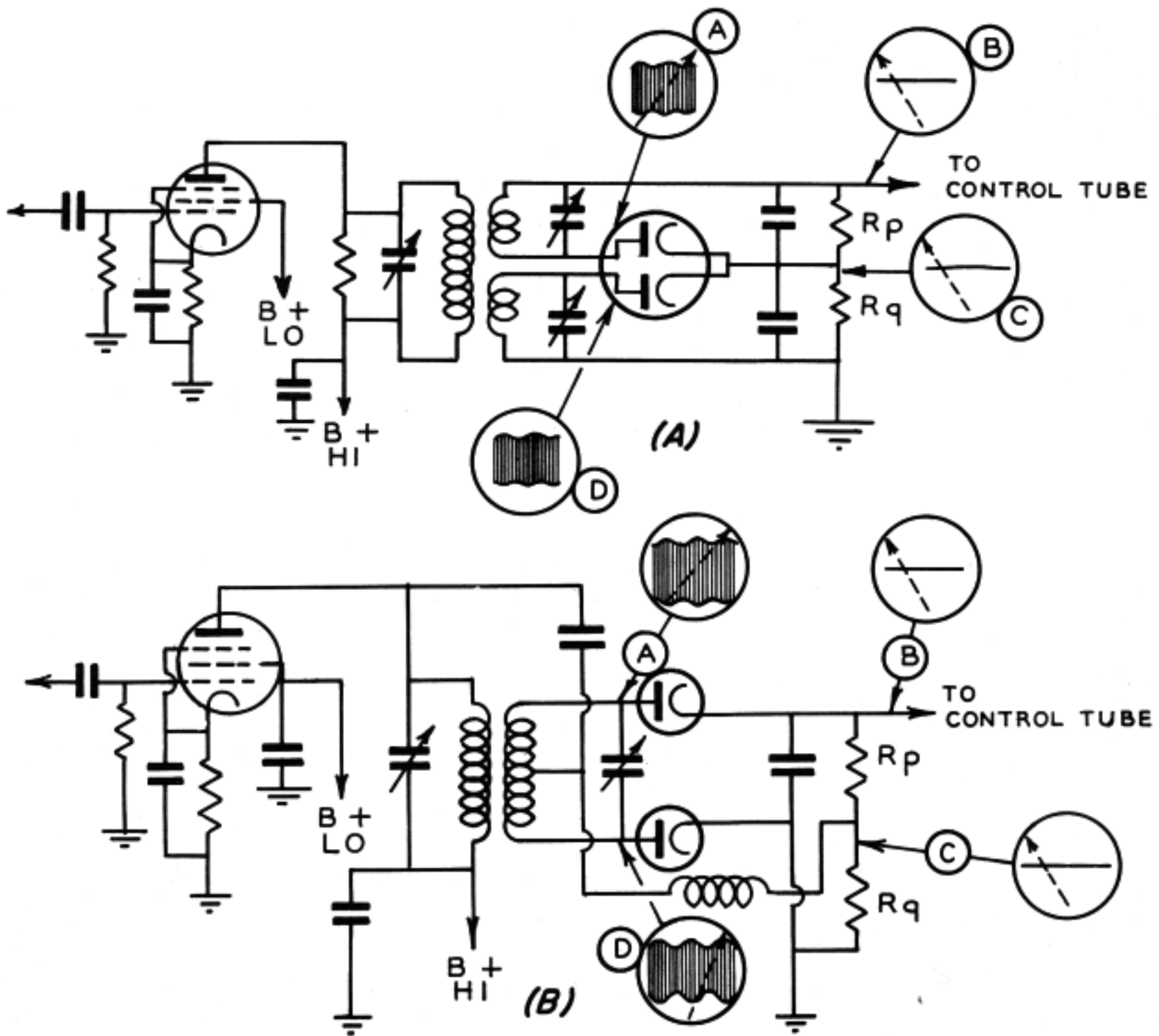

FIG.22-TWO TYPICAL FREQUENCY DISCRIMINATOR CIRCUITS FOR A.F.C. (A) IS SIDE-CIRCUIT TYPE. (B) IS PHASE TYPE.

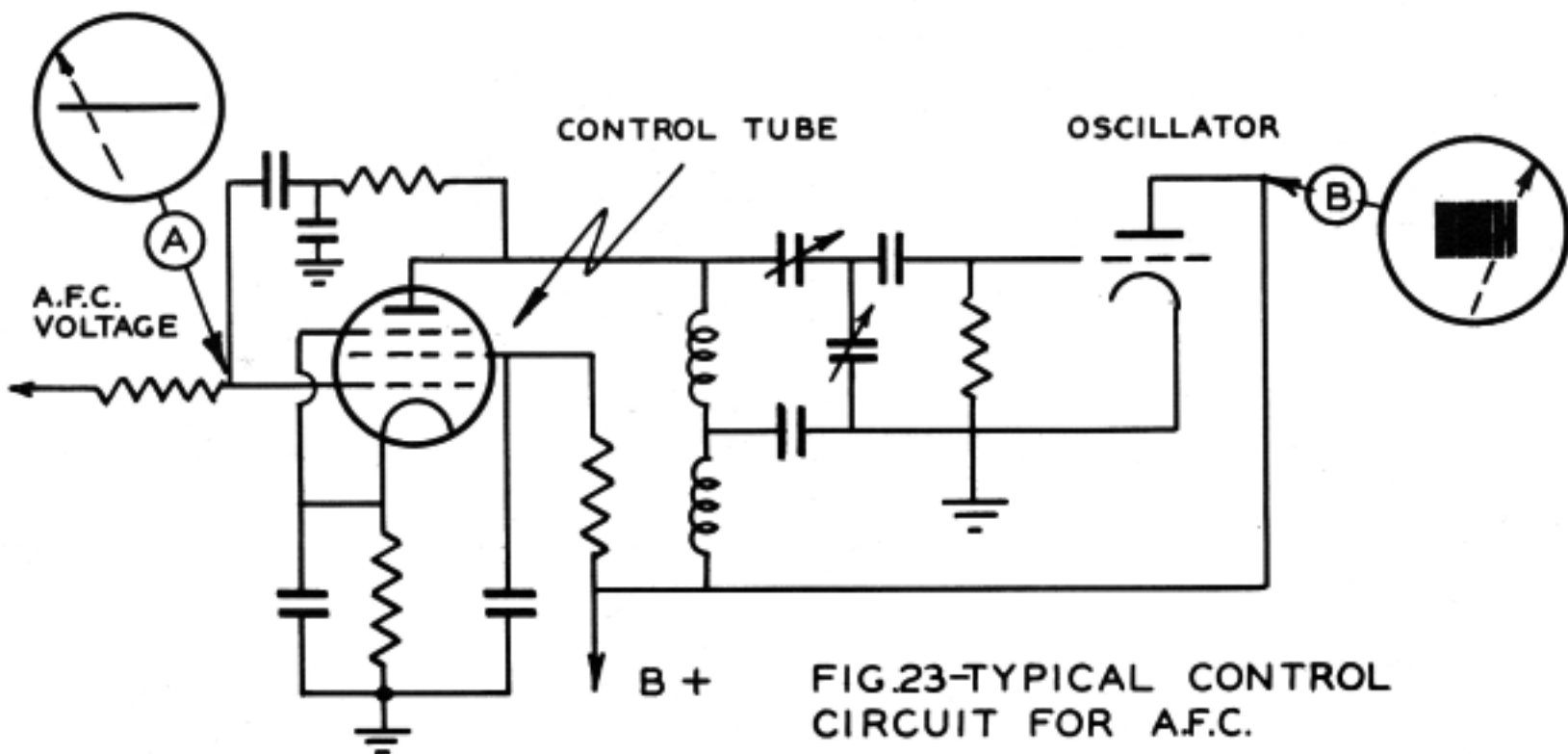

FIG.23-TYPICAL CONTROL CIRCUIT FOR A.F.C.

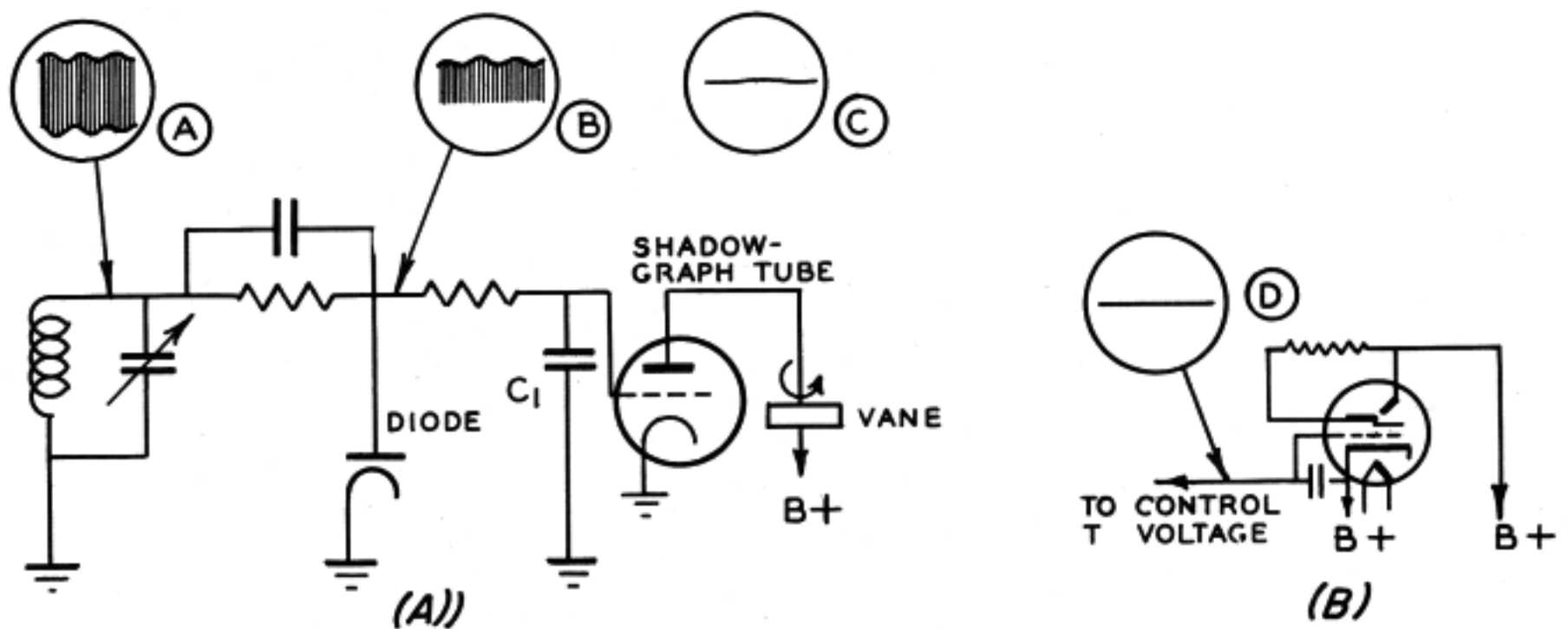

FIG. 24: TYPICAL TUNING INDICATOR CIRCUITS. (A) SHOWS SHADOW-GRAPH VANE TYPE. (B) SHOWS CATHODE-RAY TUNING INDICATOR

the modulated signal, B the rectified envelope and C should indicate an approximately straight line on the scope. Condenser C1 should tend to prevent the audio variations and the resultant d-c voltage at point C may be checked in the same manner as the AVC voltage discussed previously. This d-c voltage is usually applied to the terminals of a shadowgraph indicator or it may feed the control grid of a cathode ray tuning type tube as shown at D.

CHECKING AUDIO FREQUENCY AMPLIFIERS

In testing audio frequency amplifiers the VEDOLYZER should be set up for gain and the same operations followed as described in the procedure used with the RF and IF amplifiers. In this case an audio voltage should be applied to the input of the amplifier (supplied by

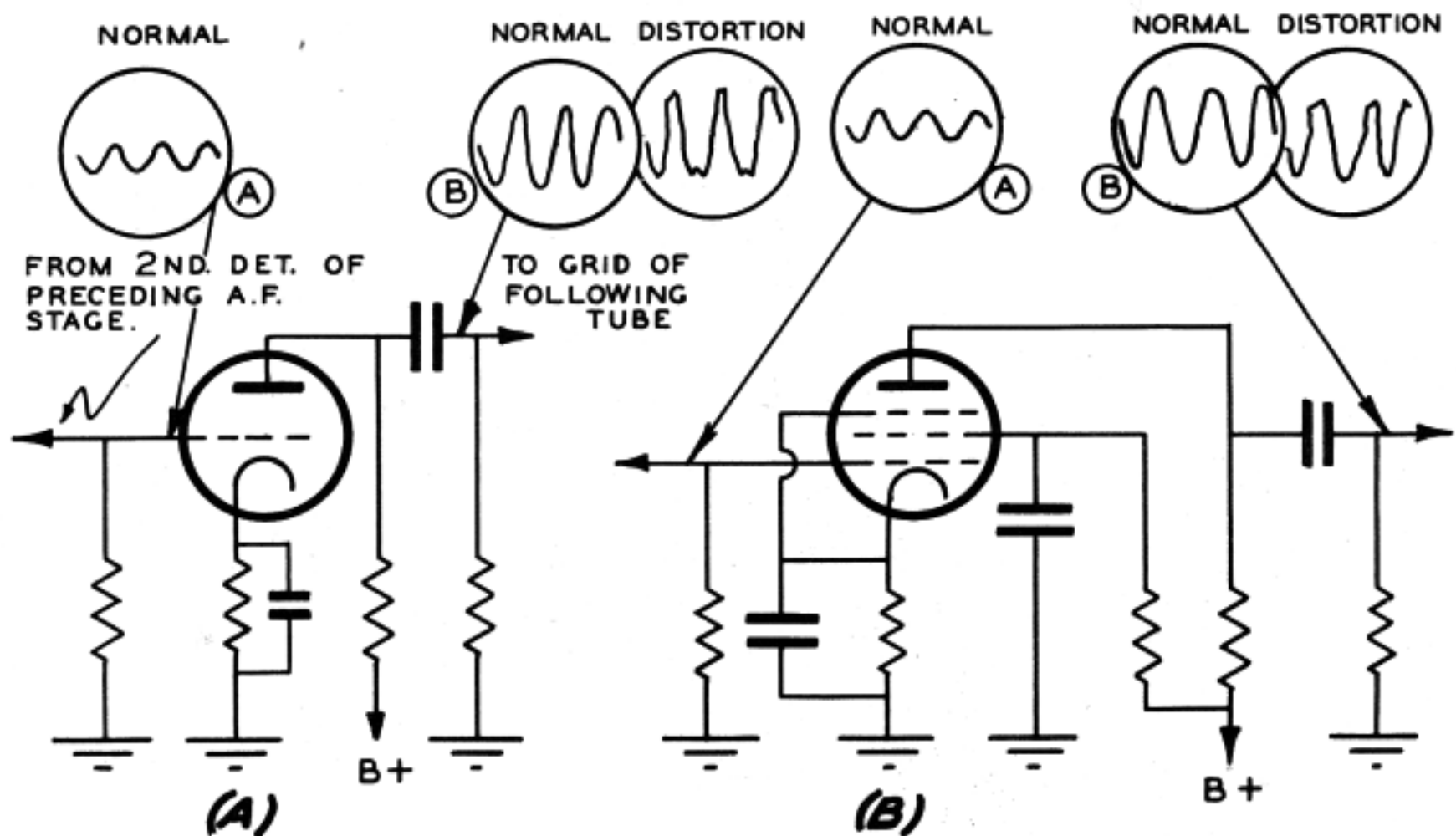
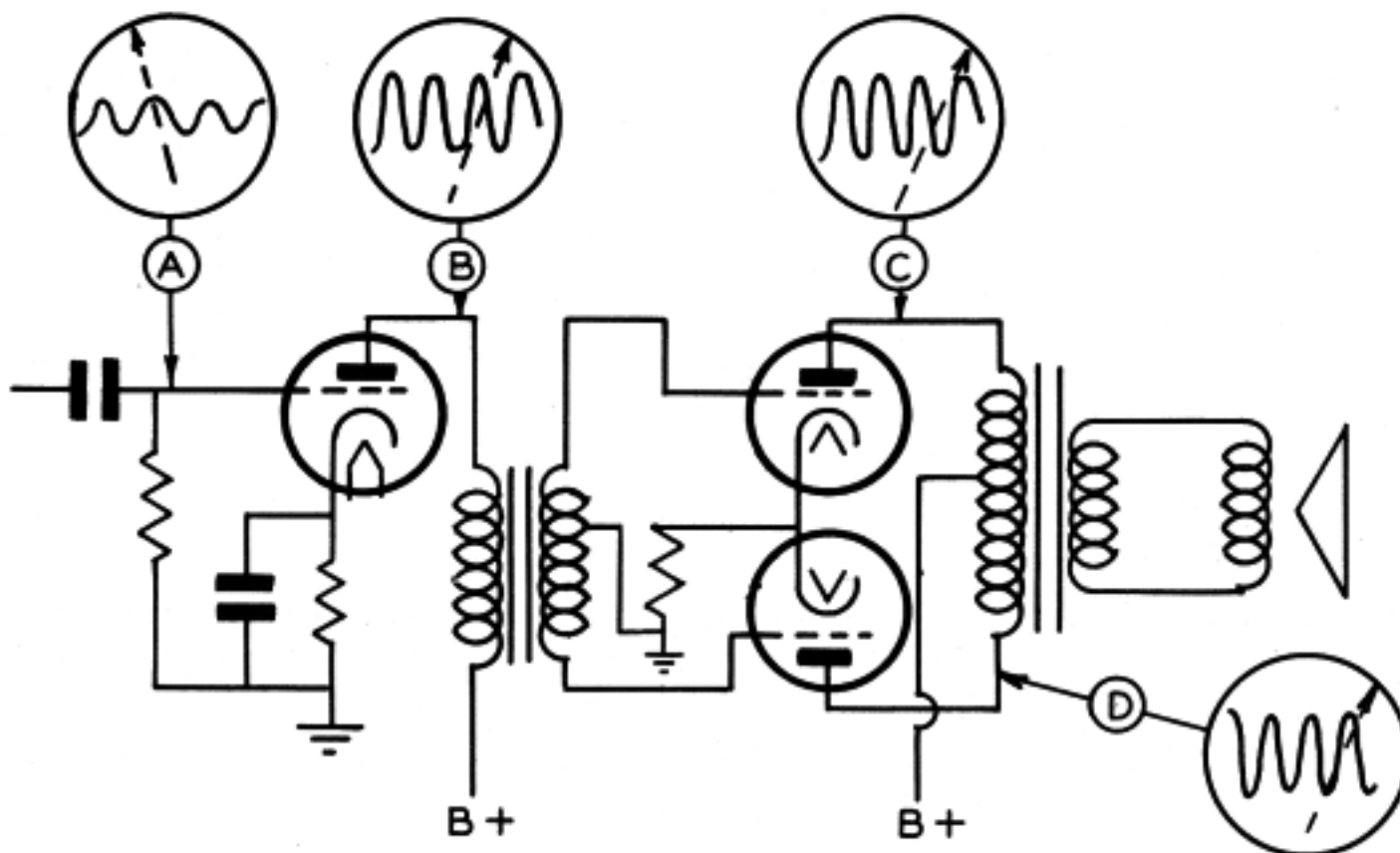

FIG. 25: TYPICAL RESISTANCE-COUPLED A.F. AMPLIFIER CIRCUITS. (A) SHOWS A TRIODE TUBE TYPE. (B) SHOWS A PENTODE TUBE TYPE.



the detector in radio receivers when using modulated signal). The operator should observe the waveform and amplification at the input and output of the stage. Fig. 25 illustrates two types of resistance coupled amplifier circuits, each receiving a sinusoidal voltage on the control grid. (A) This voltage should be similar to the output voltage of the generator or preceding stage, both in amplitude and waveform. The output is indicated by two oscillograms (B) showing the "normal" waveform and amplification and also the general form of a distorted wave.

FIG.26:TYPICAL CLASS B AUDIO AMPLIFIER

Frequently a hum voltage will be super-imposed upon these oscillograms when distortion is indicated. In this particular case the oscillator should check for the frequency of the hum and determine whether it is in the receiver power supply or introduced with the signal supply. Oscillation in the stage will be noted by a waveform similar to B which cannot be attenuated.

Fig. 26 illustrates a typical transformer-coupled triode feeding two output power amplifier tubes connected for obtaining push pull amplification. Points A and B are the same as the respective points described in Fig. 25 in the same conditions and results will apply for the transformer-coupled stage. Points C and D illustrate the voltages at the output of the power tubes and it should be noted that the oscillograms are equal and opposite or one is turned upside down from the other. A typical push pull amplifier stage

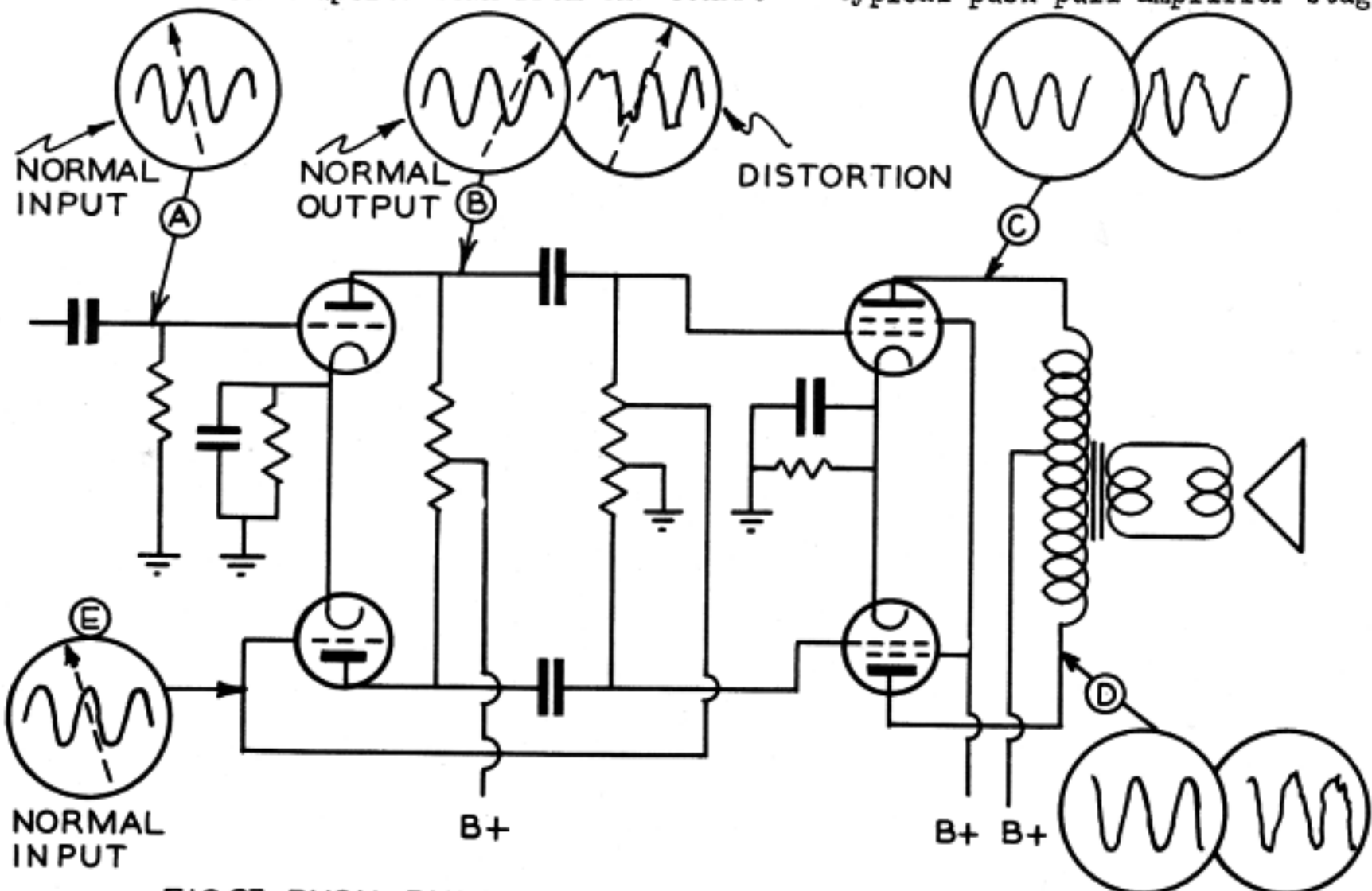

FIG.27:PUSH-PULL AUDIO AMPLIFIER WITH PHASE INVERSION

using a tube as the phase inverter is shown in Fig. 27. In both cases, the grid circuits of the output tubes will be similar in waveform and phase with reduced amplification depending upon the "mu" of the tube.

VISUAL ALIGNMENT WITH THE 'SCOPE SECTION OF THE VEDOLYZER

After the trouble in the receiver has been located and corrected most servicemen find it necessary to re-align the i-f and r-f sections and adjust the frequency of the oscillator for proper tracking. Sometimes the sections are found to be far out of adjustment, usually caused by the hands of the owner or "neighborhood genius," but more often we find the cause is natural capacity drift produced by temperature, etc.

The 'scope section of the dynamic analyzer may be used to an advantage at this point since it is the fastest method of alignment known today. If the receiver is small and does not contain wide bandpass intermediate frequency transformers, then peak or adjust the stages for maximum amplitude. In a receiver of this type it would be a waste of time to try to secure high-fidelity and selectivity. In receivers designed for high-fidelity reception, more care should be exercised to see that the stages are adjusted to the proper band width, as well as maximum amplitude. Usually manufacturers supply the alignment curve and this should be duplicated as closely as possible.

In general, connect the vertical input of the 'scope to the output of the second detector and apply a frequency modulated signal to the input of the amplifier to be aligned. When adjusting the intermediate frequency amplifiers connect the signal generator to the input of the first detector and for adjusting the r-f and oscillator, make the connections to the antenna. In any event, the 'scope must receive a rectified signal to produce a conventional resonance curve.

We will not attempt to discuss the various types of resonance curves as this subject has been in print many times before and could be nothing more than repetition. Full details may be obtained from the instructions sheets of any signal generator which has facilities for visual alignment, such as the Supreme Model 561.

FREQUENCY MODULATION RECEIVERS

Although, at the time of this writing, frequency modulation (FM) is an infant from the standpoint of production, the fact that all of the larger receiver manufacturers have models of FM sets on the market warrants some discussion on this subject. Quite a number of the higher priced sets are combination AM-FM receivers and the service technician should be equipped and versed in the art of both types of radio transmission and reception.

Regardless of the style, type or model of receiver, the owner of a Supreme VEDOLYZER should remember a few things when confronted with the servicing of the FM receiver. First, the FM receiver is a new type of set incorporating two new circuits whose action must be thoroughly understood, namely, the limiter and the discriminator. Second, it should be remembered that the VEDOLYZER, containing a cathode ray oscilloscope and vacuum-tube voltmeter, will work equally as well in a FM receiver as it does in an amplitude modulation (AM) receiver. Third, FM receivers work with frequencies which are higher than those usually found in the AM routine. Fourth, the general public has been sold on this new type of set by the advertising of a noiseless and high fidelity reception and proper servicing is essential to obtaining these features.

Checking the limiter with the VEDOLYZER: If you will examine a wiring diagram of the limiter circuit, you will see that it and the diode detector circuit of an AM receiver are much alike. They not only look alike, but do the same job of rectification. To check this circuit, set the VEDOLYZER up for signal tracing (Fig.4) with the "FUNCTION SELECTOR" in "D" position and place "R.F." probe on the plate of the limiter tube. Tune in the signal and the resulting oscillogram will be similar to "C", Fig. 20.

Alignment of FM Receivers: For the alignment of all the tuned circuits, including the discriminator, it is strongly recommended that the owner of a Model 560-A VEDOLYZER follow out the instructions given with the specific type of signal generator that he is using. Some signal generator instructions manuals will require a cathode ray scope and some will require a DC vacuum-tube voltmeter. Remember that you have both in the Model 560-A. In using the VEDOLYZER as an oscillograph, the A.F. probe should be used and connected into the circuits as dexcribed by your signal generator instructions manuals.

INDEX

	Page
FOREWORD	ii
INTRODUCTION	
The "SEE THE SIGNAL" system.....	iii
THE VEDOLYZER	
General Description of Sections.....	iv
The Vacuum Tube Voltmeter.....	iv
The Cathode Ray Oscillograph.....	v
The Dynamic Signal Tracer.....	v
The Multiple Monitor.....	v
The Wavemeter.....	v
Technical Features.....	v
Electrical Specifications.....	vi
Mechanical Specifications.....	vi
Accessories.....	vii
Panel and Components.....	vii
THE VEDOLYZER AS A COMPLETE DYNAMIC ANALYZER	
The Signal Supply.....	1
Preliminary Adjustments.....	1
The VEDOLYZER as a Multimeter.....	2
The VEDOLYZER as an Oscillograph.....	3
The VEDOLYZER as a Signal Tracer.....	4
The VEDOLYZER as a Multiple Monitor.....	19
SIGNAL TRACING WITH THE VEDOLYZER	
The Superhetrodyne Receiver.....	6
The Tuned Radio Frequency Receiver.....	9
ANALYSIS OF RECEIVER BY CIRCUITS	
The Amplitude Modulation Type.....	11
Automatic Volume Control (AVC).....	11
Power Supplies.....	12
Oscillators and Converters.....	16
Alignment.....	26
Detectors.....	20
R-F Amplifiers (including I-F).....	9
A-F Amplifiers.....	24
Automatic Frequency Control (AFC).....	22
Tuning Indicators.....	22
Gain Measurements.....	20
CHECKING INTERMITTENTS WITH THE VEDOLYZER	
Probes and Connections.....	18
FREQUENCY MODULATION RECEIVERS.....	26



SUPREME

Testing Instruments

"SUPREME BY COMPARISON"

Download Provided Free at
SupremeInstruments.org

Not For Resale