

SUPREME SIGNAL GENERATOR
MODEL 189



OPERATING DATA



SUPREME INSTRUMENTS CORPORATION
GREENWOOD, MISSISSIPPI
U. S. A.

Stock #7140

SUPREME SIGNAL GENERATOR

MODEL 109

TECHNICAL DATA

! I M P O R T A N T !

THE GUARANTEE POLICY ON YOUR SUPREME INSTRUMENT IS NOT APPLICABLE UNLESS THIS PARAGRAPH IS COMPLIED WITH!

REGISTRATION. THE RETURN REGISTRATION CARD, WHICH IS INCLUDED WITH EACH TESTER SHIPMENT SHOULD BE COMPLETED WITH THE PROPER INFORMATION AND MAILED IMMEDIATELY AFTER THE USER'S RECEIPT OF THE TESTER. IT IS THE PURPOSE OF THE RETURN REGISTRATION CARD (1) TO APPLY THE GUARANTEE POLICY IN FAVOR OF THE OWNER OF THE TESTER, AND (2) TO ASSURE THE USER'S RECEIPT OF ANY ADDITIONAL DATA WHICH MAY BE ISSUED WITH REFERENCE TO THE USE OF THE TESTER. THE ISSUANCE OF NEW DATA MAY NOT BE NECESSARY BUT IN CASE NEW DATA BE ISSUED, THE USER IS ENTITLED TO IT AND HE WILL RECEIVE SUCH NEW DATA IF HIS OWNERSHIP OF THE TESTER IS REGISTERED BY MEANS OF THE RETURN REGISTRATION CARD. THE GUARANTEE POLICY IS NOT APPLICABLE UNLESS THE TESTER IS REGISTERED WITHIN TEN DAYS AFTER ITS RECEIPT, AND THE SERIAL NUMBER OF THE TESTER SHOULD BE MENTIONED IN ALL CORRESPONDENCE.

GUARANTEE. THE TESTER IS NOT GUARANTEED UNLESS THE OWNERSHIP THEREOF IS PROPERLY REGISTERED. WHEN THE USER REGISTERS HIS OWNERSHIP OF THIS TESTER WITHIN TEN DAYS AFTER HE RECEIVES IT, THE TESTER WILL BE GUARANTEED TO BE FREE FROM DEFECTS IN MATERIAL OR WORKMANSHIP; AND ANY SUCH DEFECTS IN MATERIAL OR WORKMANSHIP WILL BE CORRECTED, WITHOUT CHARGE, WHEN THE TESTER IS DELIVERED TO THE SUPREME INSTRUMENTS CORPORATION, GREENWOOD, MISSISSIPPI, WITHIN NINETY DAYS AFTER ITS RECEIPT BY THE USER; OR, THE SUPREME INSTRUMENTS CORPORATION WILL REFUND THE REPAIR CHARGES PAID TO AN AUTHORIZED SUPREME SERVICE STATION FOR THE CORRECTION OF SUCH DEFECTS IN MATERIAL OR WORKMANSHIP UPON THE USER'S PRESENTATION, WITHIN NINETY DAYS AFTER THE USER'S ORIGINAL RECEIPT OF THE TESTER, OF A PAID INVOICE OF SUCH REPAIRS, INDICATING THE CORRECT SERIAL NUMBER OF THE TESTER AND DESCRIBING THE REPAIRS; PROVIDED THAT (1) THE FREE REPAIR OR REPLACEMENT OF MATERIALS SHALL NOT INCLUDE THE REPLACEMENT COST, OR THE INSTALLATION OF, AN INSTRUMENT RECTIFIER (ON MODELS USING SAME), WHICH ARE INCAPABLE OF WITHSTANDING APPRECIABLE ELECTRICAL OVERLOADS AND ARE NOT, THEREFORE, GUARANTEED BY THE MANUFACTURERS, AND (2) THE USER ACCEPTS THE OBLIGATION OF THE PAYMENT OF ALL TRANSPORTATION COSTS INVOLVED IN THE CORRECTIONS EFFECTED UNDER THE CONDITION OF THIS GUARANTEE POLICY, IN ACCORDANCE WITH THE STANDARD PRACTICES OF THE RADIO MANUFACTURER'S ASSOCIATION.

SUPREME INSTRUMENTS CORPORATION

GREENWOOD, MISSISSIPPI

U. S. A.

PANEL LAYOUT OF MODEL 189
SIGNAL GENERATOR

PROPER PART NAME (USED IN INSTRUCTIONS)	FUNCTION	LOCATION ON PANEL
FULL VISION DIRECT READING-TUNING DIAL	SCALE-- (A) - 100 K. C. -- 350 K. C. (B) - 350 K. C. - 1100 K. C. (C) - 1100 K. C. - 3400 K. C. (D) - 3.3 M. C. - 10 M. C. (E) - 7 M. C. - 20 M. C. (F) - 10 M. C. - 30 M. C.	CENTER OF PANEL
RANGE	SCALES-- (A), (B), (C) AND (D). SCALES (E) AND (F) ARE HARMONIC RELATIONS OF SCALE (D)	UPPER RIGHT SECTION OF PANEL
MULTIPLIER	SCALES-- "1", "10", "100" AND "1,000". UTILIZED FOR CONTROLLING THE R. F. OUTPUT OF THE GENERA- TOR	UPPER LEFT SECTION OF PANEL
ATTENUATOR	SCALE GRADUATED FROM 0 TO 50 IN DIVISIONS OF 5 MICROVOLTS. FOR USE AS A VERNIER CONTROL IN CONJUNCTION WITH THE MULTIPLIER	LOWER LEFT SECTION OF PANEL
"ON-OFF" SWITCH	A. C. POWER SUPPLY SWITCH	TO LEFT OF TUNING DIAL CONTROL KNOB
"MOD-OFF" SWITCH	AFFORDS A MEANS FOR OBTAINING AT THE OUTPUT PIN JACKS AN UNMODULATED OR MODULATED R. F. OUTPUT	TO RIGHT OF TUNING DIAL CONTROL KNOB
AUDIO FREQUENCY OUTPUT PIN JACK (RED)	AT THESE TWO PIN JACKS IS AVAILABLE A 400 CY- CLE ALTERNATING CURRENT SOURCE OF SUPPLY; WHEN THE "MOD-OFF" TUMBLER SWITCH IS SET AT THE "MOD" POSITION	RIGHT CENTER
ANTENNA HIGH TO RED PIN JACK	ACROSS ANTENNA HIGH (RED PIN JACK) AND GROUND (BLACK PIN JACK) IS AVAILABLE THE UNCONTROLLED MAXIMUM RADIO FREQUENCY OUTPUT OF THE SIGNAL GENERATOR	TO LEFT OF MULTIPLIER
GROUND	GROUND CONNECTION TO SIGNAL GENERATOR	TO LEFT OF ATTENUATOR
ANTENNA LOW (PIN JACK)	RADIO FREQUENCY OUTPUT AS USED IN CONJUNCTION WITH MULTIPLIER AND ATTENUATOR NET WORK	ABOVE GROUND PIN JACK
SERIAL NUMBER	MENTION MODEL AND SERIAL NUMBER IN ALL CORRES- PONDENCE	DIRECTLY BENEATH TUNING DIAL CONTROL KNOB

GENERAL. THE MODEL 189 SIGNAL GENERATOR IS DESIGNED TO MEET THE DEMAND FOR A COMPLETELY SHIELDED PRACTICAL SERVICE SIGNAL GENERATOR ADAPTABLE FOR GENERATING SIGNALS OVER A WIDE RANGE OF RADIO FREQUENCIES FOR ACCOMMODATING ALL OF THE SERVICE REQUIREMENTS OF COMMERCIAL SUPERHETERODYNES, TUNED-RADIO-FREQUENCY AND SHORT-WAVE RECEIVERS. THIS GENERATOR IS THE RESULT OF MANY MONTHS OF INTENSIVE EXPERIMENTAL DEVELOPMENT IN AN EFFORT TO PRODUCE A GENERATOR WHICH WOULD PROVIDE A MAXIMUM DEGREE OF UNCHANGING AND UNVARYING SERVICE CHARACTERISTICS WITH A MINIMUM OF OBSOLESCENCE PROBABILITIES. AMONG THE OUTSTANDING FEATURES OF THIS GENERATOR ARE:

1. **CIRCUIT.** AN ELECTRON-COUPLED CIRCUIT IS UTILIZED IN THE RADIO FREQUENCY GENERATOR STAGE OFFERING EXCELLENT DYNAMIC STABILITY.
2. **FREQUENCY RANGE.** CARRIER FREQUENCY OF 100 KILOCYCLES TO 30 MEGACYCLES FROM 90 KILOCYCLES TO 10 MEGACYCLES AT FUNDAMENTALS.
3. **FREQUENCY CALIBRATION.** EACH SIGNAL GENERATOR IS INDIVIDUALLY CALIBRATED BY MEANS OF TRIMMERS AND BENDING OF END PLATES, GUARANTEED ACCURACY OF 3%.
4. **ATTENUATOR.** LADDER ATTENUATOR IN CONJUNCTION WITH A MULTIPLIER ARRANGEMENT AND VARIABLE CONTROL APPROXIMATELY CALIBRATED IN MICROVOLTS.
5. **MODULATION.** SELF-CONTAINED 400 CYCLE OSCILLATOR CAPABLE OF MODULATING RADIO FREQUENCY CARRIER APPROXIMATELY 50% AND ARRANGED IN A UNIQUE MANNER TO PREVENT CARRIER "BOBBULATION".
6. **COUPLING TO ATTENUATOR CIRCUIT.** COUPLING BETWEEN OSCILLATOR PROPER AND ATTENUATOR CIRCUIT PURELY ELECTRONIC.
7. **STABILITY.** THE CALIBRATION OF THE SIGNAL GENERATOR IS INDEPENDENT OF USUAL VARIATIONS OF PLATE POTENTIALS AND EXTERNAL LOADS.
8. **CONTROLS.** FOUR CONTROLS, RANGE SELECTOR FOR SELECTION OF PROPER INDUCTOR FOR DESIRED CARRIER FREQUENCY RANGE, A FOUR INCH AIRPLANE TYPE DIRECT READING DIAL WITH A TURN RATIO OF TEN TO ONE, AND ATTENUATOR CONTROLS CONSISTING OF MULTIPLIER SWITCH AND VARIABLE CONTROL.

TUNING RANGES. A TUNING "RANGE" SELECTOR IS LOCATED ON THE SIGNAL GENERATOR PANEL FOR SELECTING ANY DESIRED TUNING RANGE BETWEEN 100 KILOCYCLES AND 30 MEGACYCLES. THIS ARRANGEMENT ENABLES COMPLETE COVERAGE OF ALL SUPERHETERODYNE INTERMEDIATE FREQUENCIES, STANDARD AMERICAN BROADCAST FREQUENCIES, POLICE TUNING BANDS, AND ALL SHORT-WAVE BANDS DOWN TO 10 METERS, WHICH INCLUDE THE POPULAR 80 METER, 40 METER AND 20 METER BANDS. EACH TUNING RANGE IS COVERED BY A VARIABLE BALL-BEARING TUNING CAPACITOR CONTROLLED BY A 4-INCH DIRECT READING AIRPLANE TYPE FRICTION DRIVE TUNING DIAL.

ACCURACY OF CALIBRATION. EACH GENERATOR IS ACCURATELY CALIBRATED WITHIN 3%; STANDARDIZED WITH FOUR ESPECIALLY DESIGNED VARIABLE FREQUENCY STANDARDS WHICH ARE CHECKED WEEKLY AGAINST WWV, THE BUREAU STANDARDS STATION LOCATED AT WASHINGTON, D. C., TO INSURE A MAXIMUM OF PRECISION.

MODULATION. MODULATION IN THE SIGNAL GENERATOR IS ACCOMPLISHED BY A SEPARATE MODULATOR STAGE TUNED TO AN AUDIO FREQUENCY OF 400 CYCLES. THIS FREQUENCY PRODUCES A PLEASING NOTE, AND ONE TO WHICH ANY ORDINARY OUTPUT METER IS VERY RESPONSIVE. THE RADIO FREQUENCY OUTPUT OF THE OSCILLATION STAGE IS MODULATED ABOUT 50% WHICH IS SOMEWHAT HIGHER THAN THE USUAL STANDARD OF MODULATION. THE FACT THAT THE PERCENTAGE OF MODULATION IS ABOUT 30% IN MOST COMMERCIAL OSCILLATORS WHEREAS THE PERCENTAGE OF MODULATION IS SOMEWHAT HIGHER IN THE MODEL 189 SIGNAL GENERATOR MAKES IT VERY ADAPTABLE FOR ADJUSTMENTS OF MODERN RADIOS IN WHICH THE BLASTING EFFECT OF STRONG SIGNALS IS MINIMIZED BY VOLUME LEVEL CIRCUITS WHICH ARE MOST EFFICIENT WHEN OPERATING WITH SIGNALS FROM A BROADCAST STATION WHICH MAINTAINS A HIGH PERCENTAGE OF MODULATION. IF STRONG R. F. SIGNALS ARE APPLIED TO A SENSITIVE RADIO OF THIS TYPE BY A POORLY-MODULATED OSCILLATOR, IT IS POSSIBLE TO OVERLOAD THE DETECTOR WITH R. F. ENERGY WITHOUT HAVING ANY APPRECIABLE LOUDSPEAKER OUTPUT OF A. F. ENERGY. IT IS, THEREFORE, OBVIOUS THAT THE LOUDSPEAKER OUTPUT IS GREATLY DEPENDENT UPON THE PERCENTAGE OF MODULATION OF THE SIGNAL GENERATOR'S CARRIER FREQUENCY.

THE "MOD-OFF" SWITCH IS PROVIDED FOR OPERATING THE GENERATOR WITH OR WITHOUT MODULATION. THIS IS AN IMPORTANT FEATURE WHEN CLOSE CHECKS ARE BEING MADE BY THE HETERODYNE OR "ZERO BEAT" METHOD, AS RECOMMENDED IN THE SERVICE LITERATURE OF SOME OF THE LEADING RADIO MANUFACTURERS.

EXTERNAL MODULATION. PROVISIONS HAVE BEEN MADE IN THE MODEL 189 SIGNAL GENERATOR FOR CONNECTING TO THE RADIO FREQUENCY GENERATING STAGE AN EXTERNAL SOURCE OF ALTERNATING CURRENT FOR MODULATION PURPOSES, RENDERING THIS FUNCTION OF THE GENERATOR IDEALLY SUITED FOR ROUGHLY CHECKING THE AUDIO FREQUENCY RESPONSE OF RECEIVERS. THE ONLY OPERATION NECESSARY IS TO SET THE "MOD-OFF" TUMBLER SWITCH TO THE "OFF" POSITION AND APPLY THE SOURCE OF SUPPLY ACROSS THE "AUDIO FREQUENCY OUTPUT" PIN JACKS.

USE OF "HIGH ANTENNA" OUTPUT TERMINALS. IN ADDITION TO THE "LOW ANTENNA" PIN JACK FOR CONNECTION TO THE REGULAR ATTENUATOR AND MULTIPLIER A THIRD PIN JACK DESIGNATED AS "HIGH ANTENNA" PROVIDES A POWERFUL RADIO FREQUENCY OUTPUT FOR NEUTRALIZING OLD TYPES OF NEUTRODYNE RECEIVERS AND, FOR PRELIMINARY ADJUSTMENTS OF RADIOS WHICH ARE BADLY OUT OF ALIGNMENT OR FOR ANY OTHER USE WHERE AN OUTPUT OF THIS INTENSITY IS REQUIRED.

SHIELDED ANTENNA CONNECTIONS. THE SHIELDED ANTENNA CONNECTOR SHOULD BE UTILIZED FOR COUPLING THE OSCILLATOR TO A RADIO IN THE FOLLOWING MANNER:

1. INSERT THE SHIELDED ANTENNA PIN PLUG IN ONE OF THE "ANTENNA" PIN JACKS (IF THE USE OF THE ATTENUATOR AND MULTIPLIER IN CONJUNCTION WITH THE RADIO FREQUENCY OUTPUT IS DESIRED THE SHIELDED PIN PLUG SHOULD BE INSERTED IN THE "LOW ANTENNA" PIN JACK).

- II. INSERT THE BLACK PIN PLUG IN THE "GROUND" PIN JACK OF THE GENERATOR.
- III. ATTACH THE ANTENNA CLIP TO THE "ANTENNA" BINDING POST OF THE RADIO, OR TO THE CIRCUIT SPECIFIED BY THE RADIO MANUFACTURERS.
- IV. ATTACH THE COPPER SPADE CONNECTOR TO THE "GROUND" BINDING POST OF THE RADIO OR UNDER SOME CONVENIENT CHASSIS SCREW. GREAT CARE SHOULD BE EXERCISED IN MAKING THIS CONNECTION, INASMUCH AS A "GOOD" GROUND CONNECTION IS ABSOLUTELY NECESSARY FOR ATTENUATION OF SIGNALS AT HIGH FREQUENCIES.

VERNIER-MOVEMENT TUNING DIAL. Each tuning range is covered by a variable tuning capacitor controlled by a 4-inch full-~~vision~~ precision slow-motion geared tuning dial. Protected against any possibility of the user forcing the dial beyond its limits thereby effecting the accuracy of the calibration by utilization of a friction type drive. By careful manipulation of the slow motion tuning dial the user will find very little difficulty in varying the tuning of the generator the few kilocycles which are necessary for the "flat-topping" or "staggering" adjustments for the intermediate stages of superheterodyne receivers. One superheterodyne manufacturer using an intermediate frequency of 170 kilocycles, recommends that the "flat topping" adjustments should be made between 165 and 175 kilocycles; that is, an adjustment of 5 kilocycles either way from the basic intermediate frequency.

FREQUENCY STABILITY. Heretofore the most undesirable feature of the A. C. operated oscillator was the inherent frequency shift due to variations in plate and filament potentials, which are incidental to power supply variations. This problem has been completely solved by employing the well known electron-coupled oscillating circuit, a major feature of which is its marked stability despite potential variations. Actual laboratory tests show that a 20% fluctuation of the filament and plate supply has no noticeable effect on any frequency setting, so that the user of the signal generator is assured that its accuracy will not be affected by normal line voltage fluctuations. A type 36 tube is used in the oscillating circuit, with the screen element operating as the plate for the oscillating circuit and the plate element acting as a coupling to the modulating stage, the coupling between the screen and plate elements being purely electronic.

AUDIO OUTPUT. The 400 cycle output of the audio oscillator, which is utilized for modulating the radio frequency generator, is made available by means of two pin jacks designated as "AUDIO OUTPUT". This feature alone is very useful inasmuch as it affords a means by which the performance of audio amplifier and P. A. systems of all designs may be checked.

WHEN USING THE AUDIO OUTPUT FOR THE ABOVE TESTS MAKE CERTAIN THAT THE "MOD-OFF" TUMBLER SWITCH IS SET AT THE "MOD." POSITION.

ATTENUATION. The attenuator is of the ladder type, consisting of a variable control and multipliers. The two controls are graduated for use in gauging the approximate micro-volt output of the generator. This arrangement provides signal voltage from a maximum of 50,000 microvolts to practically zero, affording excellent attenuation at even the highest frequency. An additional output terminal is provided which is not controlled by the attenuator system, for use when a signal intensity greater than 50,000 microvolts is desired for preliminary adjustments of radios which are badly out of alignment or for neutralizing old types of neutrodyne receivers.

SHIELDING. The problem of shielding has been carefully considered by Supreme Engineers in the design of the signal generator, as the elimination of stray fields or reduction, to a maximum of one microvolt is absolutely essential for A.V.C. alignment. This is accomplished by housing the entire unit in an aluminum case and shielding of inductors, and other component parts of the radio frequency generator.

TRANSPORTATION DAMAGES. The office of origin of the transportation agency which accepted this tester for the original shipment assured the shipper against external and concealed damages in transit. If the tester be received in a damaged condition, or if some part of the tester be damaged in transit, the user of the tester should ask the transportation agency which delivered the tester, for a concealed damage report which should be forwarded to the factory with the return registration card, for factory instructions as to the procedure which should be followed for effecting the necessary repairs or replacements.

SUPREME SERVICE STATIONS. For the purpose of effecting prompt repair of damages sustained by inadvertent misuse, or for any other reason, the services of the Supreme Service Stations may be utilized instead of returning damaged testers to the factory. A list of the Supreme Service Stations may be obtained from the Supreme factory offices. If it should be necessary to ship a tester to the factory or to a Supreme Service Station, the shipment should be made via express—never via parcel post—and a letter should be written and forwarded separately, advising of the shipment and including complete instructions as to the desired handling and disposition of the merchandise; otherwise, the merchandise may be refused by the consignee. Immediate repairs or replacements can usually be effected for customers who have not established credit; some delay may be expected on services rendered for a credit customer when it is necessary to write to the credit customer for an acceptance of the transportation and any repair or replacement costs which are not covered by the standard guarantee policy. When repairs are requested of a service station on a tester which has been registered within 10 days after its receipt, and under the conditions of the guarantee policy, the repair charges should be paid or accepted, and a copy of the Supreme invoice covering the repairs should be obtained from the service station and forwarded to the factory for any refund or credit which may be properly made under the terms of the guarantee policy.

REPLACEMENT PARTS, ETC. If some part of the tester be damaged in service, or if the user should want to order circuit drawings, analysis charts, test leads, or other accessories, his order should be accompanied by a deposit amounting to not less than fifty cents. Since an order amounting to less than fifty cents cannot be assembled, packed and shipped without financial loss, a

HANDLING CHARGE MAY BE MADE SO AS TO MAKE THE ORDER TOTAL FIFTY CENTS, INCLUDING TRANSPORTATION CHARGES. IF AN ORDER BE ACCOMPANIED BY A DEPOSIT WHICH DOES NOT COVER THE COST OF THE MERCHANDISE AND TRANSPORTATION CHARGES, THE SHIPMENT WILL BE MADE VIA EXPRESS C.O.D., FOR THE BALANCE DUE. A LIST OF REPLACEMENT PARTS MAY BE OBTAINED UPON REQUEST.

GUARANTEE. THE TESTER IS NOT GUARANTEED UNLESS THE OWNERSHIP THEREOF IS PROPERLY REGISTERED. WHEN THE USER REGISTERS HIS OWNERSHIP OF THIS TESTER WITHIN TEN DAYS AFTER HE RECEIVES IT, THE TESTER WILL BE GUARANTEED TO BE FREE FROM DEFECTS IN MATERIAL OR WORKMANSHIP; AND ANY SUCH DEFECTS IN MATERIAL OR WORKMANSHIP WILL BE CORRECTED, WITHOUT CHARGE, WHEN THE TESTER IS DELIVERED TO THE SUPREME INSTRUMENTS CORPORATION, GREENWOOD, MISSISSIPPI, WITHIN NINETY DAYS AFTER ITS RECEIPT BY THE USER; OR, THE SUPREME INSTRUMENTS CORPORATION WILL REFUND THE REPAIR CHARGES PAID TO AN AUTHORIZED SUPREME SERVICE STATION FOR THE CORRECTION OF SUCH DEFECTS IN MATERIAL OR WORKMANSHIP UPON THE USER'S PRESENTATION, WITHIN NINETY DAYS AFTER THE USER'S ORIGINAL RECEIPT OF THE TESTER, OF A PAID INVOICE OF SUCH REPAIRS, INDICATING THE CORRECT SERIAL NUMBER OF THE TESTER AND DESCRIBING THE REPAIRS; PROVIDED THAT (1) THE FREE REPAIR OR REPLACEMENT OF MATERIALS SHALL NOT INCLUDE THE REPLACEMENT COST, OR THE INSTALLATION OF, AN INSTRUMENT RECTIFIER (ON MODELS USING SAME), WHICH ARE INCAPABLE OF WITHSTANDING APPRECIABLE ELECTRICAL OVERLOADS AND ARE NOT, THEREFORE, GUARANTEED BY THE MANUFACTURERS, AND (2) THE USER ACCEPTS THE OBLIGATION OF THE PAYMENT OF ALL TRANSPORTATION COSTS INVOLVED IN THE CORRECTIONS EFFECTED UNDER THE CONDITION OF THIS GUARANTEE POLICY, IN ACCORDANCE WITH THE STANDARD PRACTICES OF THE RADIO MANUFACTURER'S ASSOCIATION.

SUPREME INSTRUMENTS CORPORATION
GREENWOOD, MISSISSIPPI
U. S. A.

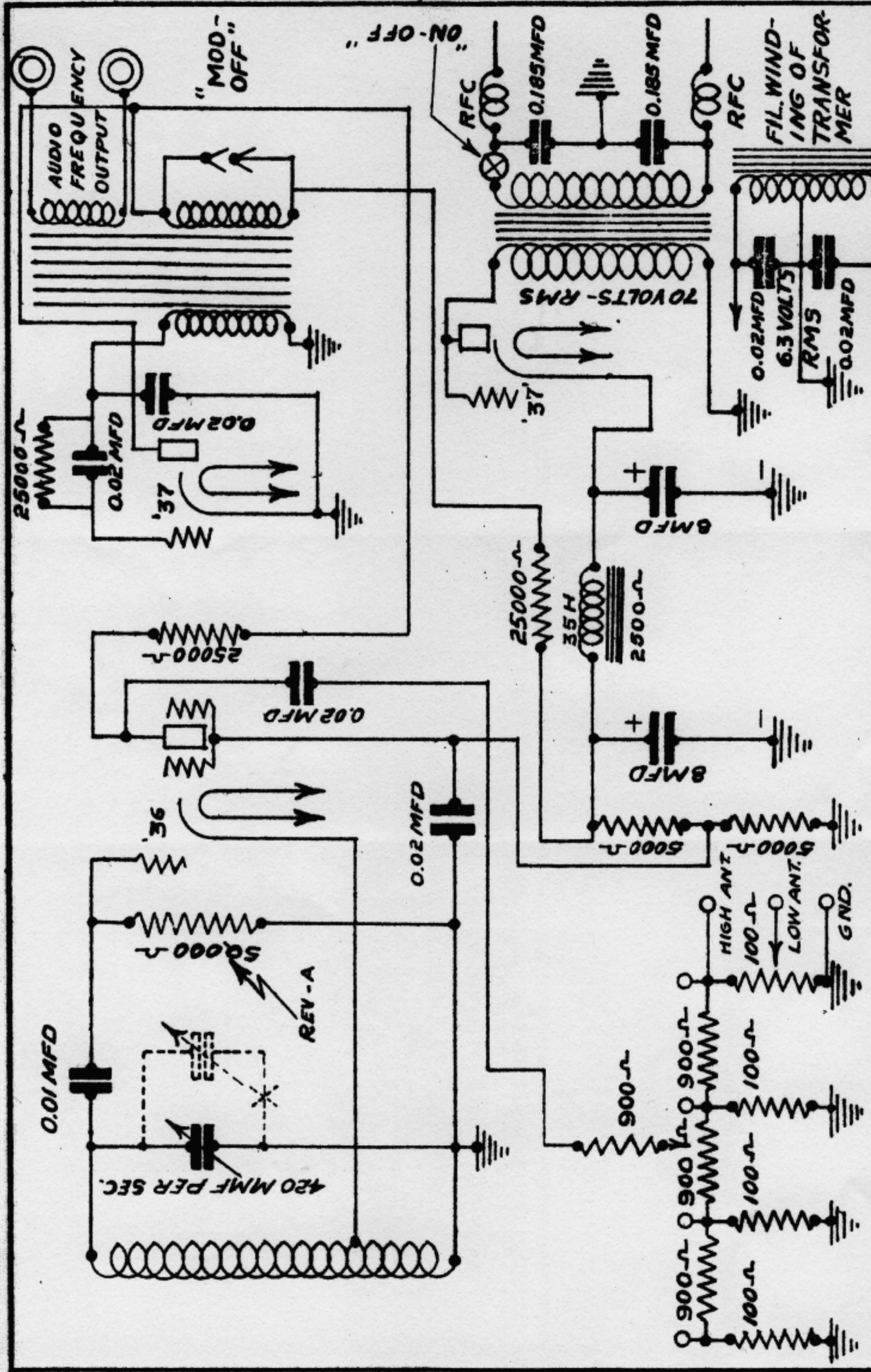

DATE 12/16/35
 REF. BY MAG
 A. B. P. 25,000-
 9-3-35

NO. 1012-A
 DATE 9-3-35
 DRAWN BY
 CHECKED BY
 APPROVED BY

MATERIAL _____ FINISH _____
 UNLESS OTHERWISE SPECIFIED DECIMAL DIMENSIONS TO BE 1/16" SCALE
 OTHER DIMENSIONS TO BE 1/8" SCALE

SUPREME
 INSTRUMENTS CORPORATION
 GREENWOOD, MISS., U.S.A.

SCHEMATIC WIRING
DIAGRAM. MODEL 189

MODEL 189 ACCESSORIES ORDER
 TO
 SUPREME INSTRUMENTS CORPORATION
 GREENWOOD, MISSISSIPPI
 U. S. A.

PLEASE SHIP TO.....
 STREET ADDRESS.....
 P. O. & STATE.....

QUANTITY	STOCK NO.	DESCRIPTION	PRICE	TOTAL
.....	6288	CHART, ANALYSIS, PER PAD OF 50	0.25
.....	1012-A	DRAWING, MODEL 189 CIRCUIT	0.15
TOTAL			

A DEPOSIT, AMOUNTING TO NOT LESS THAN FIFTY CENTS, IS ENCLOSED HEREWITH; AND IT IS UNDERSTOOD THAT, IF THIS ORDER AMOUNTS TO LESS THAN FIFTY CENTS INCLUDING TRANSPORTATION COSTS, A HANDLING CHARGE WILL BE MADE SO AS TO MAKE THE ORDER TOTAL FIFTY CENTS. IF THE DEPOSIT IS INSUFFICIENT TO COVER THE COST OF THE MERCHANDISE AND TRANSPORTATION CHARGES, YOU ARE REQUESTED TO MAKE SHIPMENT VIA C.O.D. EXPRESS FOR THE BALANCE DUE. IT IS UNDERSTOOD THAT YOUR QUOTED PRICES ARE SUBJECT TO CHANGE WITHOUT NOTICE.

.....193..... (SIGNED).....

(Stock #7310)

RECOMMENDED RADIO PUBLICATIONS

RIDER'S MANUALS - JOHN F. RIDER
SERVICING SUPERHETRODYNES - JOHN F. RIDER
PUBLISHED BY - JOHN F. RIDER, PUBLISHER
1440 BROADWAY, NEW YORK

ELEMENTS OF RADIO COMMUNICATION - JOHN H. MORECROFT
EXPERIMENTAL RADIO ENGINEERING - JOHN H. MORECROFT
PUBLISHED BY - JOHN WILEY & SONS, INC.
440 4TH AVENUE, NEW YORK

RADIO PHYSICS COURSE - ALFRED GHIRARDI
MODERN RADIO SERVICING - GHIRARDI AND FREED
RADIO FIELD SERVICE DATA - GHIRARDI AND FREED
PUBLISHED BY - RADIO TECHNICAL PUBLISHING COMPANY
22 WEST 21ST STREET, NEW YORK

SOUND MOTION PICTURES RECORDING & REPRODUCTION
SERVICING SOUND EQUIPMENT
PUBLIC ADDRESS SYSTEMS
BY JAMES R. CAMERON
PUBLISHED BY - CAMERON PUBLISHING COMPANY
WOODMONT, CONN.

PROJECTION SOUND PICTURES - AARON HADELL
PUBLISHED BY - MCGRAW - HILL BOOK COMPANY
330 WEST 42ND STREET, NEW YORK

MODEL 189
PRECISION MULTI-WAVE SIGNAL GENERATOR
PACKING LIST

EFFECTIVE OCTOBER 24, 1935

ACCESSORIES INCLUDED IN ORIGINAL MODEL 189 SIGNAL GENERATOR SHIPMENTS.

QUANTITY:	STOCK :			PACKER'S
INCLUDED:	NUMBER:		DESCRIPTION	CHECK
1	: 6725	:	CARD, 3 x 5" REGISTRATION	: ✓
1	: 6208	:	CHART, SAMPLE ANALYSIS	: ✓
1	: 7394	:	CONNECTOR, 6 FT. SHIELDED ANTENNA	: ✓
1	: 7140	:	DATA, MODEL 189 OPERATING	: ✓
1	: 7310	:	FORM, MODEL 189 ACCESSORIES ORDER	: ✓

THE ABOVE LIST OF ITEMS HAS BEEN CHECKED BY THE UNDERSIGNED WHO IS RESPONSIBLE FOR THE COMPLETION OF THIS PACKAGE.

.....1545408.....
(SERIAL NUMBER)

(SIGNED).....*SPJ*.....

*THE SERIAL NUMBER OF THE SIGNAL GENERATOR IS LOCATED DIRECTLY BELOW TUNING DIAL KNOB AND SHOULD BE MENTIONED IN ALL CORRESPONDENCE PERTAINING TO THE SIGNAL GENERATOR.

SUPREME INSTRUMENTS CORPORATION
GREENWOOD, MISSISSIPPI
U. S. A.



www.StevenJohnson.com

**Antique Technolgy, Tube Radios and Test Equipment
Vintage Schematics, and Publications**

Steve's Antique Technology