

The
SUPREME
391 P.A.
ANALYZER

The Supreme Model 391 P. A. Analyzer

By Harold H. Shotwell

A NEW field of virtually unlimited possibilities for the progressive, modernly equipped serviceman has quietly and steadily grown up in the last few years. It is the extension of sound equipment and public speaking address systems. Invariably sound equipment is an invaluable and indispensable asset of its owner. For example, motion picture theatres, auditoriums, stadiums, schools, hotels, restaurants and dance pavilions, to name only some of the more important installations.

Catering to a critical public, the owners of sound equipment realize the vital importance of keeping their installations in perfect operating condition. Even the small neighborhood talkie operator knows how quick defective sound will close

his doors. That's why servicing this type of equipment brings much more substantial rewards per job to the radio serviceman.

The new Supreme Model 391 P. A. Analyzer has been expressly designed, engineered and constructed to provide reliable facilities in one instrument for checking, testing and servicing every part of any type of sound equipment. You can confidently choose it with the assurance that myriad minute checking and cross-checking for every known type of problem in every kind of sound installation has been incorporated in its capacities. In fact that the Supreme 391, in the characteristic fashion of all Supreme test equipment, simplifies sound servicing, makes mastery of this new service technique within the reach of every intelligent radioman.

THE METER

In order that space, weight and final cost should all be as low as possible, a single D. C. meter with associated rectifier was selected in place of a separate meter for A. C. measurements and another for D. C. measurements. The meter sensitivity was chosen so as to give a full scale deflection with a current of 200 microamperes. This gives

a readable deflection on currents of the order of 2 to 4 microamps or better, such as encountered in photo-electric cell circuits in motion picture sound systems. These currents are easily read on the larger, wider angle scale such as is used on the Supreme fan-shaped meter.

METER FUNCTIONS

Before determining the associated circuits and their constants, it is necessary to ascertain the various uses to which the instrument may be put.

These uses, as determined by the characteristics of sound equipment, include the following:

Measurement of direct currents, from photo-cell circuits to exciter lamp currents.

Measurement of direct and alternating current voltages from tube biases to high voltage rectifier windings.

Determining of effective resistances from speaker

voice coil windings to grid leaks and plate coupling resistors.

Measurement of capacities from small grid couplers to large by-pass and filter condensers of both electrolytic and non-electrolytic types.

Determining of the level of audio currents and voltages in their decibel relations to the accepted reference level.

The above measuring functions must be available either for internal use in analyzing tube circuits and constants, or for external use, by means of test probes.

CURRENT MEASUREMENTS

The currents to be measured vary in magnitude from a few microamperes to at least 10 amperes. Obviously, this great range cannot be covered by one meter without resorting to multipliers.

Fig. 1 shows the basic current measuring circuit. R_m is the meter resistance, R_{se} is the series arm of the total shunt resistance R , R_{sh} is the

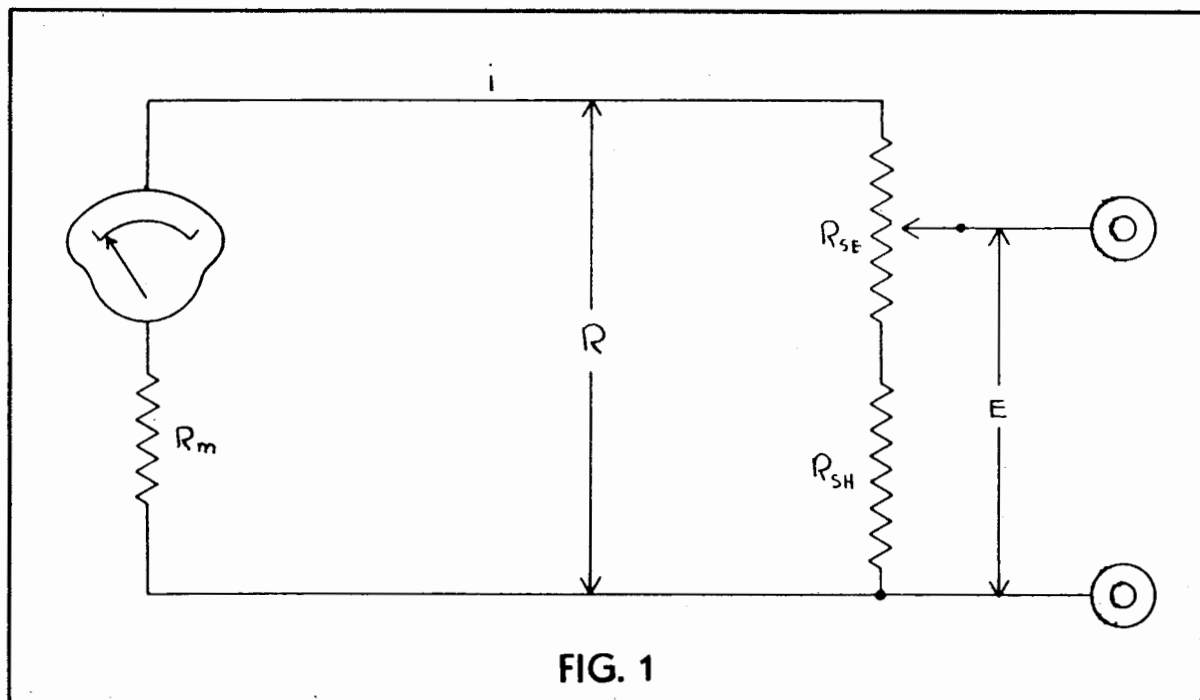

FIG. 1

Use Diagram

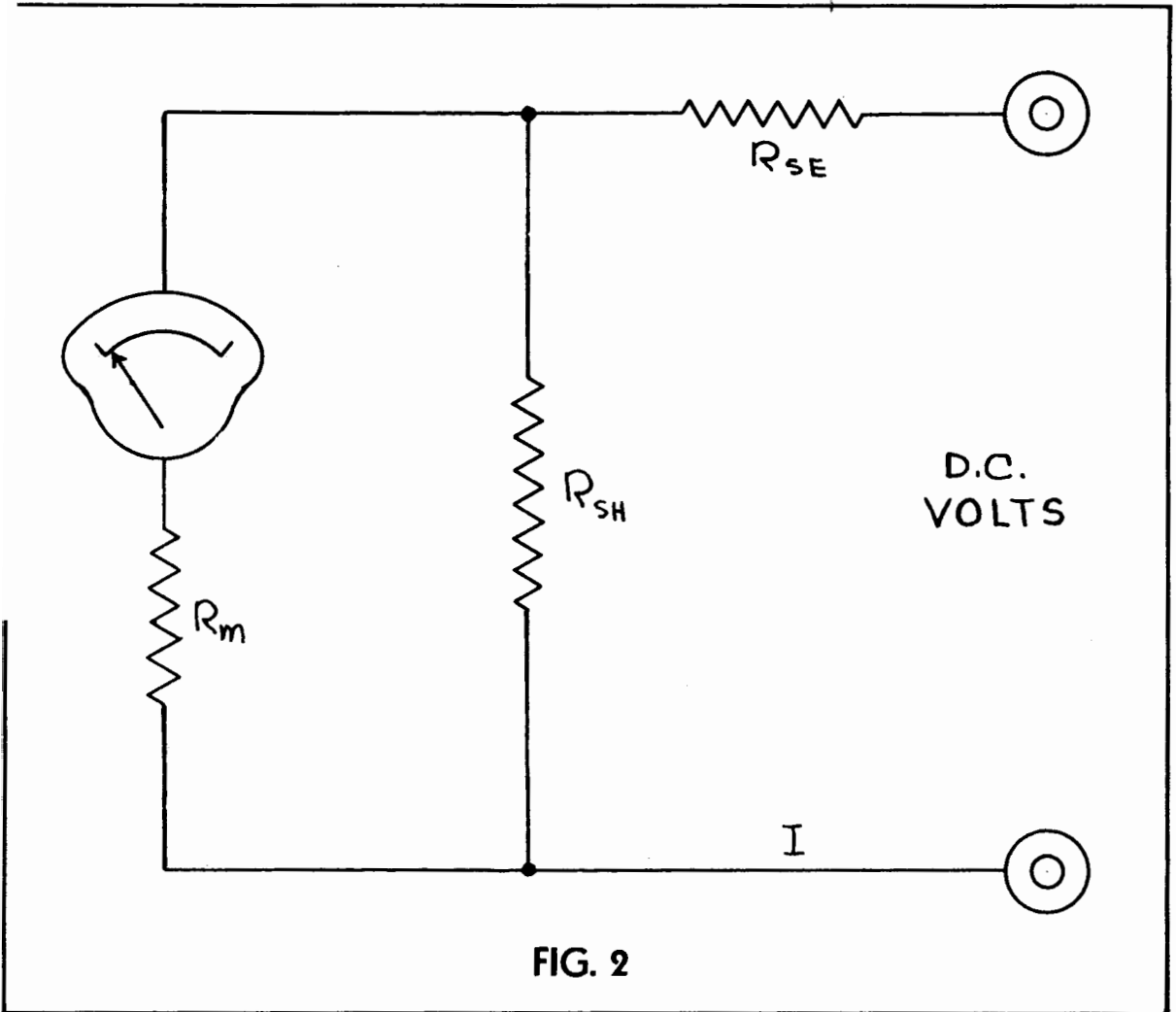

FIG. 2

shunt resistance portion of R , (i) is the current through the meter, and I is the current being measured.

By means of a multi-point switch, the proportion of R_{se} to R_{sh} is varied from 0, ($R_{se} = 0$, and $R_{sh} = R$), to several thousand, in order that

I may vary from a few milliamperes to several amperes.

R_m is the total meter resistance, including a calibrated resistor in series with the actual moving coil so as to raise the combined resistance to a predetermined value, thus allowing the other circuit constants to remain fixed.

VOLTAGE MEASUREMENT

(1) D. C. Voltage. The highly sensitive meter is readily adaptable to the measurement of low and high D. C. voltages, by using proper series multipliers for absorbing that portion of the voltage which is not required across the meter.

Desiring a resistivity of at least 1000 ohms per volt, and with a low range scale of 0 to 5 volts, we find our circuit resistance, including the meter resistance, to be 5000 ohms, and the circuit current to be $5 \div 5000$ or 1 milliampere. But, one milliampere will produce a 400% overload on the meter, hence it is shunted by a resistor of $\frac{1}{4}$ the meter resistance.

Then the total resultant resistance of the meter and its parallel shunt is used in calculating the series multiplier. For the 5 volt range this is as

follows: Referring to Fig. 2, R_{se} is the series multiplier resistance. We know the current I for full scale deflection is 1 ma. The meter resistance R_m is arbitrarily set as before mentioned at 600 ohms. Therefore R_{sh} (the meter shunt) is 150 ohms. R_{sh} and R_m in parallel equal

$$\frac{600 \times 150}{600 + 150} = 120 \text{ ohms.}$$

Now by Ohms Law, $R_{total} \frac{E}{I}$, equals $\frac{5}{.001} = 5000$ ohms. But from R_{total} must come the meter and shunt resistance of 120 ohms, leaving a value of 4880 ohms for R_{se} . Other ranges are calculated in a similar manner.

(2) A. C. Voltages. As the meter is of the standard D'Arsonval type, a rectifier must be used when measuring A. C. voltages. The current will

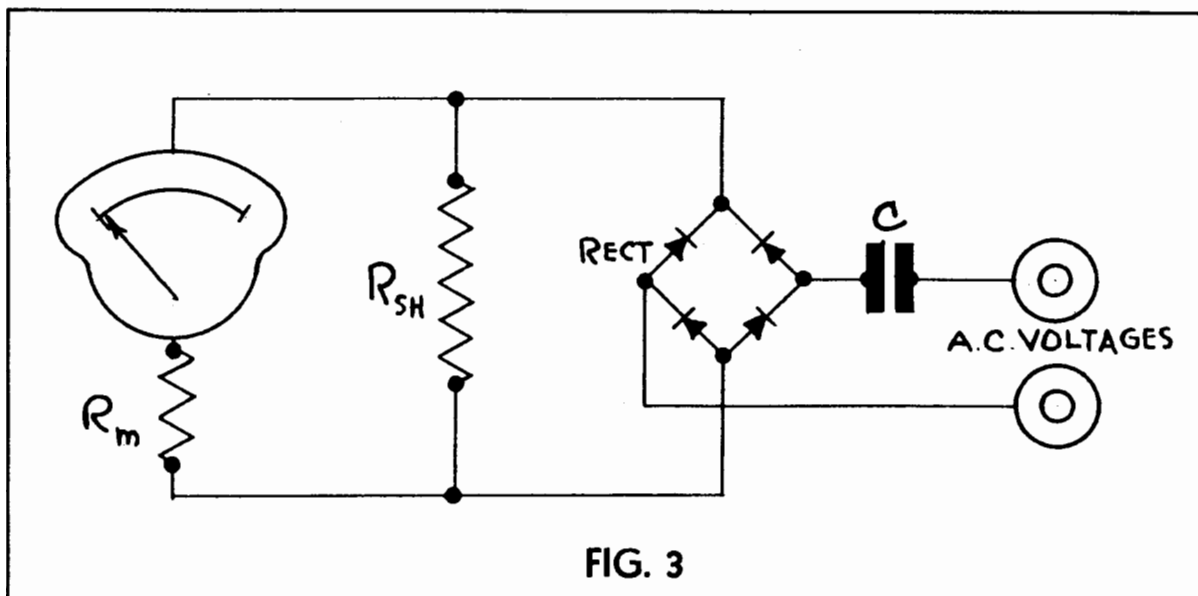

FIG. 3

still remain at 1 ma. for full scale deflection, with a 1000 ohms per volt sensitivity.

However, because the wave form of the rectified A. C. is such as to give average rather than R. M. S. values, the meter shunt resistor R_{sh} , Fig. 3, will have to be increased by an amount sufficient to allow a rectified current of approximately 1.11 x 0.2 ma. or 0.222 ma. through the meter for full scale deflection.

Considering the rectifier, it is unfortunately a fact that the rectifier resistance varies considerably with the amount of current passing through it. Hence, in order to have true readings we would have to resort to a special meter scale which would compensate for the rectifier resistance variations.

However, if we insert a capacitor C, Fig. 3, in series with the rectifier, and use its reactance for our multiplier, we will have a resultant current which is but slightly affected by the rectifier resistance, inasmuch as the drop across the resistance is in quadrature with that across the capacitor. Hence we can retain our evenly divided meter scale, as the current through the capacitor is proportional to the voltage.

This negligible effect of the rectifier resistance variation is shown by the following calculations. The meter and its shunt have a resultant resistance of 132 ohms. The rectifier resistance at 0.5 ma. (for half scale deflection) is approximately 700 ohms, hence the total $R = 832$ ohms.

Considering the 5 volt A. C. range, we have

$I = \frac{E}{Z}$, or $.001 = \frac{5}{Z}$, where Z is the impedance of the circuit between the terminals. Therefore $Z = \frac{5}{.001}$ or 5000 ohms. But $Z = \sqrt{R^2 + X_c^2}$, hence $\sqrt{832^2 + X_c^2} = 5000$, or $832^2 + X_c^2 = 25 \times 10^6$ and $X_c^2 = 25 \times 10^6 - 832^2 = 25 \times 10^6 - 692224 = 24307776$ and $X_c = 4935$ ohms, from which $C = .537$ mfd. for 60 cycle voltages.

If, however, the rectifier resistance changes from 700 ohms to say 1100 ohms, as it might with a smaller current flowing, what would Z then be? Substituting values we have $Z = \sqrt{1232^2 + X_c^2} = \sqrt{1232^2 + 24307776} = \sqrt{1517824 + 24307776} = \sqrt{25825600} = 5085$ ohms.

The percentage of error introduced would be $\frac{85}{5000} = 1.7\%$ which is acceptable.

If a pure resistance were to be used in the above case for the multiplier, its value would be

$$R_t = \frac{5}{.001} = 5000 \text{ ohms}$$

$R_{mult} = 5000 - (132 + 700) = 5000 - 832 = 4168$ ohms.

Then if the rectifier resistance changed to 1100 ohms with a decrease in current, our total circuit resistance would be $4168 + 132 + 1100 = 5500$ ohms, and the error would be $\frac{500}{5000}$ or 10%.

Hence the advantage of using the capacitor multiplier is easily seen.

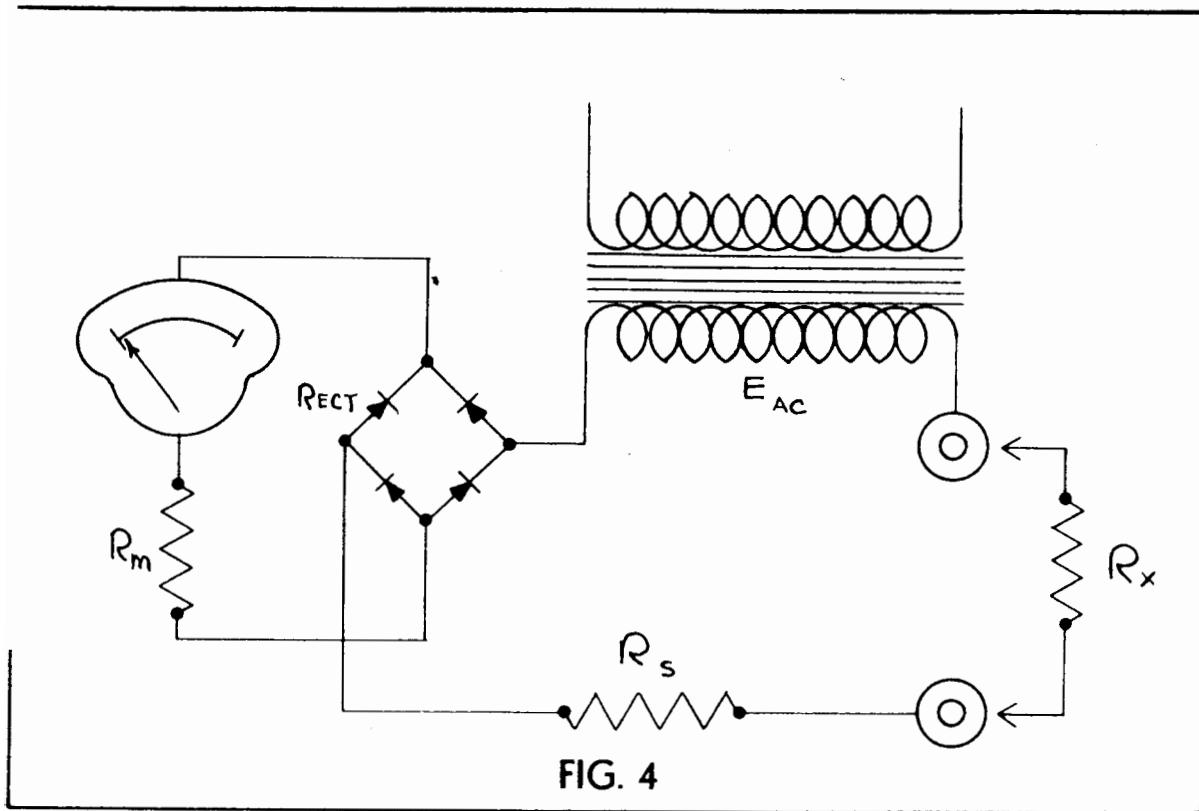

FIG. 4

A capacitor is also used for the 25 volt range, and here, because of the higher reactance of the capacitor, the rectifier resistance variation has even less effect. On the ranges above 25 volts,

straight resistance multipliers are used, inasmuch as the change in total resistance due to rectifier resistance variations is only a fraction of a percent at the worst.

RESISTANCE MEASUREMENTS

For assisting in locating possible sources of trouble in sound equipment, it was considered necessary to include means for checking effective resistances ranging from a few ohms to many megohms. If a direct current source of voltage were used, it would necessitate external batteries to make the higher ranges available. However, by

utilizing the meter in combination with the rectifier, it is found possible and feasible to supply the necessary voltage from an inbuilt transformer.

The method consists of applying a known voltage to the unknown resistor in series with the meter and rectifier, and noting the meter deflec-

tion. A source of 2 volts is used to measure all resistors up to 500,000 ohms. Above this value the voltage is increased in order to produce a sufficient current through the higher resistance to give proper meter deflections.

Fig. 4 shows the basic circuit. E_{ac} is the source

of voltage, R_s a series resistance to balance the meter circuit against the unknown resistor, R_x . If R_x is 0, or the terminals are shorted, full scale deflection will be had, indicating zero ohms. When there is any resistance at R_x , the meter deflection will be dependent upon its value, hence can be calibrated directly in ohms.

CAPACITY MEASUREMENTS

Sound equipment also embodies capacitors whose value is often desired. Again utilizing the source of A. C. voltage, and placing the unknown capacitor in a series circuit, as shown in Fig. 5, the meter deflections will be dependent upon the value of the capacity. For different ranges, a different E_{ac} is used so as to obtain satisfactory meter deflections for any capacitor in that range.

For the higher values of capacity, that is, those larger than 0.1 mfd. or so, the currents through the capacitor become too large to be passed through the meter, hence the meter is shunted. Also, a tapped shunt is provided ahead of the rectifier so as not to overload this device. Fig. 6 shows the basic circuit. E_{ac} is limited to 10 volts so as not to damage high capacity low voltage electrolytic by-pass capacitors.

DECIBEL MEASUREMENTS

Facilities are provided in the Model 391 for direct measurement of the power level in decibels

in a 500 ohm line up to plus 35 DB with respect to the accepted zero level of 6 milliwatts.

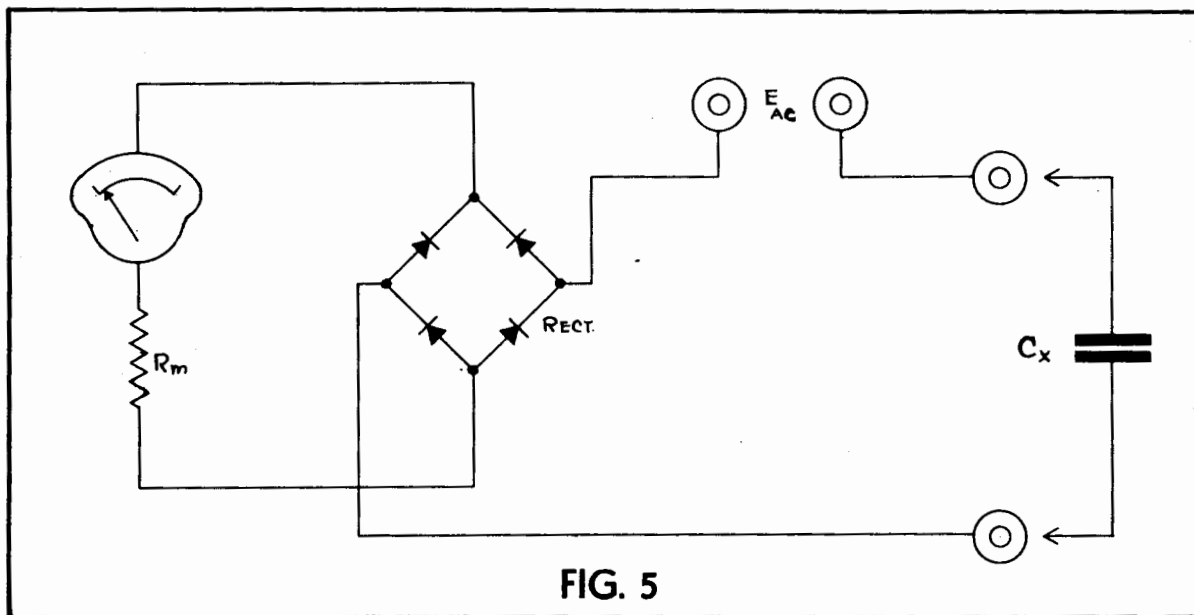

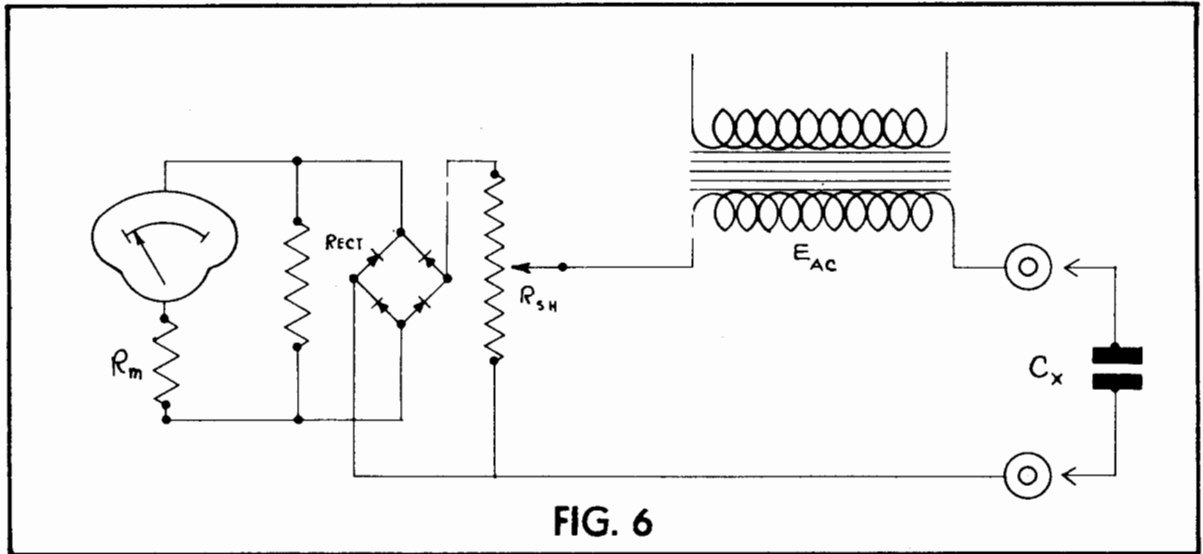

FIG. 6

Essentially the circuit is, as shown in Fig. 7, similar to an A. C. voltmeter circuit, Resistors R_1 and R_2 limit the current to acceptable values for satisfactory meter deflections. The meter, however, has a portion of its scale specially calibrated in decibels, obtained by calculating the meter current flowing when the test probes are across a 500 ohm line, with a given power level therein.

Arbitrarily choosing plus 35 DB as the top level we wish to measure, this being approximately 19 watts, what is the voltage across the line?

Taking the Decibel formula:

$$DB = 10 \log \frac{P_2}{P_1} \text{ we have } 35 = 10 \log \frac{P_2}{.006}$$

$$\text{or } \log \frac{P_2}{.006} = 3.5.$$

Referring to our logarithm tables, we find the anti-log of 3.5 to be 3162.3, hence $\frac{P_2}{.006} = 3162.3$ and $P_2 = 3162.3 \times .006$ or 18.97 watts.

$$\text{Then, as } P = \frac{E^2}{Z}, E = \sqrt{PZ}, \text{ and } E = \sqrt{18.97 \times 500}$$

$$= \sqrt{9485} = 97.5V.$$

Thus we determine $(R_1 + R_2)$ in Fig. 7 so as to limit our current to .001 A. through the meter and rectifier, (R_{sh} being shunted across the meter

passing .0008 A.), as follows:

Resultant meter and R_{sh} resistance = 132 ohms.

Rectifier resistance at .001 A. = 400 ohms.

$$\text{Therefore } R = \frac{E}{I} = \frac{97.5}{.001} = 97500 \text{ ohms.}$$

$$(R_1 + R_2) = 97,500 - (132 + 400) = 96,968 \text{ ohms.}$$

R_2 is calculated similarly by arbitrarily assuming a full scale deflection for 20 DB in the 500 ohm line.

Then, with the circuit constants determined, the percentage meter deflection for any DB level can be calculated by obtaining the voltage developed by that level, and determining what current this will produce through the meter.

Zero level of 6 milliwatts in a 500 ohm line is the accepted reference level. However, lines of various other impedances are often encountered, and the meter may also be used for ascertaining the level in these lines, by adding or subtracting the number of decibels given by the relation

$$DB = 10 \log \frac{500}{Z_L}$$

where Z_L is the impedance of the line under test. If Z_L is more than 500 ohms, the sign of the resultant number of DB's will be negative, indicating

a subtraction of that number from the meter reading. If Z_L is less than 500 ohms, the number of DB's will be positive and should be added to the meter reading.

A chart showing actual line DB's in terms of meter DB's for various common line impedances, accompanies each Model 391 Tester.

TUBE CIRCUIT ANALYZING

All amplifier tube circuits can be accurately checked by the point-to-point method. Any tube, including the new 8-prong metal types, or metal tubes of less number of pins, is removed from its socket, and put into the proper socket on the Model 391 panel. The analyzer plug on the end of its multi-conductor cable is placed into

the vacant tube socket, thus bringing all the tube circuits to the tester, where the current flowing through any element, or the potential of that element to any other element, can be readily read. Also while the tube is in the tester, its condition can be instantly determined by means of the grid-shift method.

A FEW USES

Photo-electric cells may be checked in two different ways by the Model 391. (1). By inserting the microammeter directly in one side of the cell circuit, the current flowing can be ascertained both with the cell dark and with full illumination. A good cell shows a considerable difference between the two readings, the exact amount depending upon the type and make of cell. Or, (2), with a frequency reel running through the projector and the Decibel meter connected to the output line of the amplifier, exact decibel differences between cells can be obtained by noting the output for

equivalent portions of the film, all other variables and control settings being the same.

Battery charging and Tungar Bulb Rectifiers can be tested by inserting the D. C. ammeter in the top clip lead of such rectifier bulb.

By using the frequency reel which is furnished as a separate accessory to the Model 391, the overall frequency characteristic of the entire sound system in a projection booth can be obtained. The Decibel meter is connected to the output line, and the readings for each frequency are noted. The results show the variation in

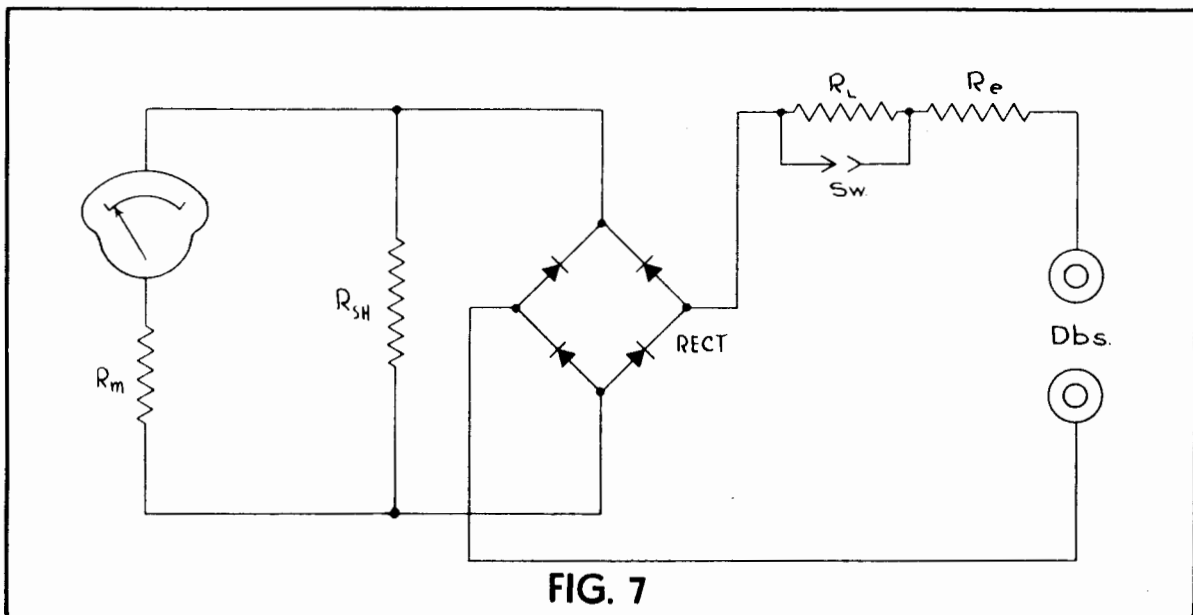

FIG. 7

response for the different frequencies directly in DB.

Using this same set-up, the image of the light slit in the optical system in the sound head can be accurately adjusted. As the frequency film is running through the projector the optical system is continuously adjusted to give maximum meter readings for each frequency, and is then locked in position after obtaining the maximum decibel reading on the highest frequency.

Also, notwithstanding the fact that the Model 391 Tester was designed primarily for sound equip-

CONTROLS

By means of a rugged seven-position rotary switch, the meter is connected into its various circuits so as to be available for the several measuring functions explained above. The rectifier and the various shunts are automatically connected when this switch is rotated.

A 6-position range selector switch, Fig. 8, on back cover, makes it easy to instantly select any range of the meter for any of its functions except the Decibel ranges. The latter are controlled by a 2-position toggle switch.

A line adjusting switch is provided, connecting to the tapped primary of the inbuilt transformer which can be set for any line voltage from 98 to

AN INSURANCE POLICY FOR EVERY THEATRE OWNER

Here is an Insurance Policy for every theatre owner using sound equipment. A complete sound equipment tester which will tell everything about any part of the talkie system. Periodical use of this new tester will eliminate breakdowns, rectify noisy systems and give that clear crispness

ment testing, it is admirably adapted to use by those radio service men who desire an instrument with the added features and ranges which the Model 391 embodies.

Satisfactory arrangements are provided for checking sets embodying the new 8-prong metal tubes, with switches for properly connecting in the filaments, which are not always in the same place on tubes of different numbers of pins. Provisions have also been made for utilizing the center stud as a ninth contact if it ever becomes necessary, thus preventing obsolescence on this type of tube.

125. Adjusting this is accomplished quite simply by putting the meter in the "OHMS" position and depressing the "Zero Ohms" switch. If the meter does not show zero, adjust the line adjusting switch until it does. Proper voltage is then being delivered to the different circuits for the various measurements.

The meter is properly protected by a high speed fuse, replaceable from the top of the panel; and the rectifier is protected against surges by a normally closed switch shorting it out until the operator is ready for the actual measuring

Fig. 9, also on back cover, illustrates the scale of the meter of the Model 391.

to speech, smoothness and naturalness to music so much desired.

The 391 has been especially designed for use in the theatre. It is simple in its operation, yet completely and easily makes all tests and checks necessary for 100% excellent sound equipment operation. The projectionist can operate it himself and keep his own equipment in shape.

Dealers Net Cash Wholesale Price **\$69.95**

Supreme Instruments Corporation
Supreme Building Greenwood, Mississippi

Export Dept. Associated Exporters Co., 145 West 45th St., New York City, Cable Address, LOPREH, New York



www.StevenJohnson.com

**Antique Technolgy, Tube Radios and Test Equipment
Vintage Schematics, and Publications**

Steve's Antique Technology